

NOVA
REPORT

2022

2024



Preface

You have before you the 2022–2024 edition of the NOVA triennial report. With it, we continue our tradition of producing a comprehensive report on our national collaboration once every three years, presenting the major developments in our research, instrumentation and outreach programmes. Contributions to this report have been provided by a large number of NOVA members, in both the research and the instrumentation sections. The report also includes updated information on our organisation, prizes and grants awarded to members of our collaboration, PhDs awarded and an overview of our finances. We believe that it is important to present our organisation and the progress we have made over these three years to the outside world and to maintain a record of our activities for posterity.

The three years this report covers have been, for the most part, very positive for NOVA. Since the start of NOVA, now more than 25 years ago, a key concern has always been the temporary nature of the collaboration and, in particular, its funding. The five-year funding cycle of the “Top Research School” programme made it difficult to create long-term stability for our instrumentation groups that are absolutely critical for the very large projects NOVA participates in and which take place over increasingly long timescales. A top priority of the 2021–2030 decadal Strategic Plan for Astronomy in the Netherlands was therefore to make NOVA permanent. With the awarding of the Sectorplan grant in 2022, providing long-term funding for the core NOVA organisation, this goal has finally been achieved.

While the award of the Sectorplan grant is a very important milestone, the new funding comes with limitations: it is substantially lower (–40%) than our previous grant and can only be used for permanent positions. As a consequence, the NOVA research program is unfunded as of 2024. This program, where PhD and postdoc positions and overlap appointments at the four partner universities were supported through NOVA, provided strategic coordination and agility that have been a key pillar under the success of NOVA. A solution for this remains our top priority, which we will continue to pursue in the coming years.

A highlight of the period of this report has been the beautiful results produced by the James Webb Space Telescope, launched on Christmas Day 2021. Many of the results include contributions from NOVA researchers, demonstrating a core tenet of NOVA’s strategy: to participate in instrumentation development to ensure priority access and optimal preparation for our research. This report includes a special feature dedicated to our involvement in the MIRI instrument on JWST and the scientific results this produced.

The most important ingredient in the success of NOVA is the diverse mix of talented and motivated people that form our community. Sprinkled throughout the report you will therefore find portraits of some of them, providing a more personal perspective on who we are and what we do. We hope that you will find the report not only informative, but also enjoyable to read.









Scott Trager
Scientific Director



Michiel Rodenhuis
Executive Director

Table of Contents

	Introduction	06
<hr/>		
	Mission and Structure of NOVA	13
<hr/>		
	The people of NOVA	15
<hr/>		
	NOVA Networks	22
<hr/>		
	Instrumentation Development	49
<hr/>		
	Communication, Education & Public Outreach	70
<hr/>		
	PhDs in Astronomy	79
<hr/>		



01

Introduction



Introduction

We are fortunate to live in a very special time: Research in our field has shown that the Universe is 13.8 billion years old. Humans have evolved in only the last tiny fraction of that time, and in an even smaller period have developed the means to study the Universe beyond the bounds of our planet. In just the last few decades, enormous strides have been made in this study: the European-led Planck mission has mapped the cosmic microwave background to make the most detailed ‘baby picture’ of the Universe; radio and far-infrared observations have allowed us to peer into the early stages of the evolution of our Universe and its galaxies; instrumentation (with key NOVA involvement) on the ESO 8.2m Very Large Telescope (VLT) and the Atacama Large Millimeter Array (ALMA) has contributed to our current understanding of the formation and evolution of stars and galaxies; new technology has opened an entirely new field of exoplanet research; and only a few years ago, the first image of the shadow of a black hole was recorded. NOVA, the Netherlands Research School for Astronomy, has played a key role in many of these discoveries and is at the forefront of this ‘golden age of astronomy’.

NOVA’s leading role has been achieved thanks to our proven method of educating top talent and providing them with access to top facilities, producing top research. To quote our Peer Review Committee, which conducted a thorough evaluation of NOVA in 2023: “Astronomy in the Netherlands is world leading in many research areas” and NOVA carries out “outstanding science”. In the evaluation report, the committee also wrote: “The NOVA program has an impressive record of educating and inspiring people, of all ages, about astronomy, training world-class talent and collaborating with industry”.

This triennial report for the period 2022–2024 presents the progress we have made in astronomical research, instrument development, outreach and engagement with society over these three years. NOVA has become a mature organisation with long-term funding and celebrated its 25th anniversary as a funded research organisation in 2024. Organisationally, NOVA has been stable over the three-year period of this report. As part of the normal turnover of positions, Scott Trager took over as Scientific Director from Amina Helmi in the fall of 2023 and Peter Jonker replaced Gijs Nelemans as Deputy Scientific Director in the summer of 2024. Michiel Rodenhuis has continued as Executive Director.

With the funding from our new Sectorplan grant starting in 2022, NOVA now has a stable financial outlook, albeit at a substantially lower level than during the previous period of five-year grants. NOVA continues to plan and execute its program in five-year cycles, with Phase 6 starting 1st of January 2024. The new Sectorplan funding has allowed us to issue a new call for instrumentation proposals, with funding allocated to 9 different proposed projects. For the most part, these are studies and seed funding projects that strategically position us to participate in a new generation of major projects in the future. Due to limitations of the Sectorplan funding, NOVA is unable to support a new Phase 6 research program. Astronomical research within NOVA of course continues, with positions funded at the four NOVA institutes through individual grants. The lack of a centrally funded and coordinated research program however puts severe limits on the coherence and strategic flexibility of our research.

¹ The origins of NOVA go back further, as it was in fact founded in 1992.

Major developments of the NOVA program 2022 – 2024

Phase-6 of NOVA's five-year planning cycle began at the start of 2024. The instrumentation program continued its strong progress towards the completion of several major projects and the full flowering of the ELT projects and the ALMA Band 2 receiver development and production. Even as the direct funding of the NOVA research program was ended with the end of NOVA's Phase-5, our research community produced a wide variety of important and exciting new results.

The launch of the James Webb Space Telescope mere days before the start of the reporting period led to many NOVA-led discoveries across several fields, including:

- Confirmation that known low-mass galaxies at high redshifts could in fact be responsible for reionising the Universe
- The most comprehensive census of the AGN-dominated 'little red dots' galaxy population at high redshifts
- The detection of complex organics, including ethanol, and identification of two sulfur-bearing ices for the first time in ices in pre-stellar molecular clouds, demonstrating that prebiotic chemistry can begin very early in the process of star and planet formation
- The observation that protoplanetary disks around the very-low-mass stars that host most of the rocky exoplanets known to date are full of small hydrocarbons and in fact have carbon-to-oxygen ratios much higher than disks around more massive solar-type stars
- The theoretical interpretation of JWST observations of 55 Cnc e, revealing for the first time the atmosphere of a lava world.

Many of these results were made using observations with MIRI, which was built in part by NOVA.

Further exciting results from NOVA researchers included:

- ALMA observations of galaxies at Cosmic Dawn as part of the REBELS survey revealed the first statistically meaningful view of obscured star formation and interstellar medium conditions in massive galaxies in the young Universe, deep in the era of reionisation; and ALMA observations of galaxies at Cosmic Noon confirmed that regularly-rotating cold disks were already present in massive galaxies at this early epoch.
- Observations of neutral hydrogen in ultra-diffuse galaxies, dwarf-mass galaxies but with disks the size of the Milky Way's, revealed that these galaxies may not need much if any dark matter, a serious puzzle for models of their formation.
- Gaia continued to provide a wealth of details on the complexity of our own Milky Way, including the detection of yet more substructures in the Galaxy's halo and the discovery of the most-metal poor stellar stream yet found.
- Euclid was launched midway through the reporting period, on 1 July 2023, and in preparation, the KiDS survey published new cosmological parameter constraints that confirmed again the tension between more local measurements and Planck's parameter inferences from the cosmic microwave background. Euclid started its survey on 14 February 2026, and it is expected to help clarify this tension in the coming years.
- The FLAMINGO suite of cosmological simulations, some of the largest hydrodynamical simulations yet performed, was a significant upgrade on previous simulations and provided a gold mine for galaxy evolution studies. The new code package SWIFT, developed to link the disparate physics packages required for the FLAMINGO simulations, has become the bedrock of a new generation of cosmological simulation codes around the world.
- A large number of massive stars escaping from the young massive star cluster R136 in the Large Magellanic Cloud were found in Gaia data,

revealing two different channels of dynamically–ejected runaway stars, one from the birth of the cluster itself and the second from an interaction of R136 with another cluster. As nearly one–third of the most–luminous stars in R136 are runaways, this discovery is changing the perception of runaways in shaping and heating the interstellar medium and driving galactic outflows.

- Social media had an unexpected positive impact on astronomy when an amateur astronomer found that a star had suddenly become twice as bright in the infrared two years before a well–studied complex optical dimming of the star. NOVA researchers joined together with the amateur astronomer to reveal that the brightening and subsequent eclipse were most likely due to the collision of two ice–giant planets in the system.
- A NOVA–led team used data from NASA’s Juno mission to probe Jupiter’s interior, demonstrating that the planet remains inhomogeneous to much greater depths than previously understood and challenging long–standing models of Jupiter’s formation.
- The first direct image of the shadow of the black hole in the centre of our Milky Way, Sgr A*, was released by the Event Horizon Telescope Collaboration, with strong leadership from NOVA astronomers and contributions from across the Dutch astronomical community. Further observations of the shadow of the black hole in Messier 87, M87*, were analysed by NOVA researchers, showing a shift in its asymmetric brightness pattern, confirmed by more recent data on M87*.
- NOVA scientists probed the dynamic radio sky, discovering pulses from a magnetised white dwarf in orbit around a brown dwarf; locating a fast radio burst in a globular cluster orbiting the galaxy Messier 81; localising a repeating fast radio burst source; finding dozens of fast radio burst sources, which are very similar to nearby neutron star bursts; and finding a new class of ultra–fast radio bursts of only microseconds duration.
- Using a combination of X–ray and radio observations, the speed of a neutron–star jet was measured for the first time to be 40% of the speed of light — significantly slower than most black hole jets.
- NOVA researchers discovered a clear link

between the accreting corona and the relativistic jet in a microquasar.

- A NOVA–led team mapped the size of the nearest millisecond pulsar, a spinning neutron star, using data from the NICER telescope on the International Space Station and placed strong constraints on the dense–matter equation of state and its magnetic–field geometry.
- The nanoHertz gravitational wave background was detected for the first time by measuring the difference in pulsar timing across the sky in an experiment involving many NOVA astronomers.
- NOVA astronomers played key roles in characterizing the brightest long–duration gamma–ray burst ever observed, using observations from JWST and HST and many other telescopes.

The period 2022–2024 has been very busy in the NOVA instrumentation program. For the optical–infrared instrumentation group, a number of major projects are in the final phase: the WEAVE spectrograph was officially inaugurated in October 2023, and the HARPS3 and 4MOST projects are close to delivery. As these projects have ramped down, the focus of the group has firmly shifted to the ELT projects, mainly METIS and MICADO. Both projects passed their Final Design Review in 2024 and are now fully in their manufacturing phase. To facilitate this, we have opened a dedicated manufacturing centre, NOVA MAX. New funding has been obtained for our ELT programme through the 18M€ Roadmap grant in 2023, with the majority being invested in the next–generation ELT projects MOSAIC and PCS.

Throughout these three years, the sub–mm group has been engaged in developing and producing the ALMA Band 2 receivers. These are the first generation of wide–bandwidth, low–noise amplifiers to be installed as part of ALMA’s Wideband Sensitivity Upgrade. NOVA also continues to be involved in many projects taking place outside the two instrumentation groups, notably our participation in the science ground–segments of the Gaia, Euclid and JWST–MIRI space observatories.

Among all these highlights, one stands out: in January 2024 a NOVA delegation had the opportunity to accompany the Minister of Education, Culture and Science, Prof. Robbert Dijkgraaf, on a visit to the ESO telescopes in Chile. This visit coincided with the inauguration of the BlackGEM array on La Silla. Accompanied by the ESO Director General, Prof.

Xavier Barcons, and the Dutch Ambassador to Chile, Ms. Carmen Consalves, the delegation also visited the VLT telescopes at Paranal, the ELT under construction at Cerro Armazones and the ALMA array on the Chajnantor plateau. The culmination of the trip came after the return to the Netherlands, when questions in Parliament prompted the minister to present pictures of BlackGEM and ESO's telescopes while explaining the strong role the Netherlands plays in these projects through NOVA.

As always, we are very proud of the many NOVA researchers who received awards and honours for their work in the period 2022–2024. These include:

- Ewine van Dishoeck received the Niels Bohr Prize (2022)
- Ignas Snellen received the Spinoza Prize (2022)
- Tim Lichtenberg received the Branco Weiss Fellowship (2022)
- Ed van den Heuvel received the Langerhuizen Oeuvre Prize (2023)
- Katharine Mulrey received the Langerhuizen Bate (2023)
- Mariano Méndez received the Jocelyn Bell–Burnell Inspirational Medal (2023)
- Heino Falcke received the Balzan Prize (2023)
- Nienke van der Marel and her team received the New Horizons Prize (2023)
- The African Millimeter Telescope Mobile Planetarium team received the Royal Astronomical Society Annie Maunder Medal for outreach (2024)
- The JWST–MIRI team, including Ewine van Dishoeck, Jan Willem Pel, Inga Kamp, Rieks Jager, Bernhard Brandl, Fred Lahuis, Gabby Aitink–Kroes, Menno de Haan, Rik ter Horst, Eddy Elswijk, Auke Veninga, Marchel Gerbers, Niels Tromp, Johan Pragt, Menno Schuil, Sjouke Kuindersma, Jan Kragt, Rens Waters, Ramon Navarro, Peter Roelfsema, Paul van der Werf, Karina Caputi, Michael Mueller, Juan Rafael Martinez Galarza, Sarah Kendrew, Huib Visser, Bob Kruizinga, Wilfried Boland, Ton Schoenmaker, Michael Meijers, Sandra Eggens, Evert Pauwels, and Lilian Leusink, received the Royal Astronomical Society Group Achievement Award (2024)
- Conny Aerts received the Crafoord Prize (2024)
- Samaya Nissanke received the AAS HEAD Mid–Career Prize (2024)
- Alex de Koter received the inaugural Kees de Jager Prize (2024)
- Jacco Vink received the Humboldt Prize (2024)
- Sera Markoff was elected to the Royal Dutch Academy of Science in 2024.

GRANT	2022	2023	2024
ERC Advanced	Hoekstra	Fraternali Hessels Jonker	
ERC Consolidator		Miguel Hodge	Rowlinson Starkenburger
ERC Starting			Callingham
ERC Synergy		BlackHolistic (Falcke e.a.)	
EU MSCA postdoctoral fellowship	Raj	DeVine	Chatterjee

NWO-VICI	Caputi	Kriek	Rossi Vidotto
NWO-VIDI		van Velzen	Haffert McClure
NWO-VENI	Roestel Chuang	Buoinfante Laplace Mancera Piña Parthasarathy Pleunis Rizzo	
NWO Roadmap		ELT (Snellen e.a.) LISA/ET (Wise e.a.)	
WINC (previously NWO-Groot)			AMT (Falcke e.a.)
NWO ENW XL	Watts Kuijken e.a.		
NWO-ENW M Invest			Hoekstra
NWO-M2	Kenworthy & Miguel Koopmans e.a.	Tolstoy	
NWO-M		Vidotto	van der Tak
NWO-XS	Fraternali	McKean	
NWO DAN III		Kamp e.a.	
NWO ISOTOPES	Snellen		
NWO-GO	Miguel		
NWO Athena	Moscibrodzka		
NWO Aspasia		Starkenbug Mulrey	
NWO Rubicon	Pastor Marazuela	Zhang	
EU HORIZON RADIOBLOCKS	van Langevelde e.a.		
ERC MSCA Doctoral Networks	Brown		
EU COFUND EVOLVE			van der Tak e.a.

Grants (selection)



**Elise
Koo**

Can you tell us about your most recent discovery or a recent development you are excited about?

A planet's magnetic field can protect its atmosphere from stellar radiation, but detecting these fields is very challenging. My research focuses on uncovering planetary magnetic fields through magnetic star-planet interactions, which can produce low-frequency radio emission. Using LOFAR, such emission has been detected from several M dwarfs. Through spectroscopic follow-up, I search for close-in planets that could generate these signals. While no clear candidates have been found yet, the search continues, and I am excited to explore more LOFAR data for additional radio-emitting M dwarfs and potential star-planet interactions.

How do you experience being an astronomer in the Netherlands and being part of NOVA?

Being an astronomer in the Netherlands has been a great experience. The country's small size is a real strength, making collaboration much easier. I realized this during last year's HARPS3 community day, when researchers from across the Netherlands came together to coordinate the most effective use of the instrument. I also particularly enjoy how NOVA makes it easy to meet other PhD students through events like the NOVA Network meetings and the NOVA PhD school. Running into familiar faces regularly is a fun way to build a network and learn about research across the country.

What do you hope to achieve in your professional work over the next year, and what role could NOVA play?

Over the next year, I aim to finish processing the circularly polarised LOFAR Two-Metre Sky Survey (V-LoTSS), and hope to find more radio-emitting M stars, which could be candidates for star-planet interactions. Now in the second year of my PhD, I also hope to deepen knowledge, skills, and connections I started building last year. NOVA plays an important role in this by providing opportunities to interact with other researchers across the Netherlands and stay connected with the wider astronomy community.

If you could share one message about astronomy with the general public, what would it be?

Astronomy is just really cool. It lets us explore the big questions about the universe, like where we come from, how it works, and our place within it. But it also benefits all of us in ways we might not always notice, driving the development of advanced technologies and instruments that often have practical applications beyond astronomy. At the heart of all these discoveries are regular people who work to make these discoveries happen, and it's important that they have the support and resources they need to keep making progress.

02

Mission
and Structure
of NOVA



The Netherlands Research School for Astronomy (NOVA) is the alliance of the astronomical institutes of the universities of Amsterdam, Groningen, Leiden, and Nijmegen, and was founded in 1992. Since 1999, NOVA has received funding as a top-research school. All university researchers in astronomy are part of NOVA. The research within NOVA is focused around the theme “The life-cycle of stars and galaxies: from high-redshift to the present”. This theme consists of three research networks:

Network 1:

Formation and evolution of galaxies:
from high redshift to the present

Network 2:

Formation and evolution of stars and planetary systems

Network 3:

Astrophysics in extreme conditions

These three research themes are inter-university, dynamic and interconnected and have been chosen strategically. The Netherlands has a track record of excellence in these research areas.

The top research school grant continued to enable NOVA to work as a (virtual) institute of top quality worldwide until the end of 2023, at which time the Sectorplan grant became the primary funding source for NOVA. The national coordination is manifested in excellent cohesive research projects and a highly synergetic instrumentation program, allowing NOVA to have a large international impact. The development and construction of advanced instrumentation has enabled university astronomers to participate in big international instrumentation projects and high-tech industry in the Netherlands to benefit from early R&D. The instrumentation program is mainly focused on optical, (near-) infrared and submillimeter instrumentation for the European Southern Observatory (ESO). In this way, NOVA functions as the home base to ESO as well as taking up the role of industry liaison. Astronomy is extremely visible in the national news channels (according to a scientific study, it is the most prominent field using data from the five major Dutch newspapers). This is thanks in large part to the work of the NOVA Information Centre which regularly issues press releases about the most exciting scientific results and endeavours of our community.

03

The people
of NOVA



NOVA is defined by its people. Their expertise, curiosity and dedication drive our scientific achievements. Throughout this report, twelve colleagues share their stories, offering insight into the work and motivation behind our community.

NOVA is an international organisation spanning nearly all age groups, bringing together researchers and staff from across the world. This breadth of backgrounds strengthens our science. At the same time, our community does not yet fully reflect the diversity of society.

Gender representation has improved steadily over the past fourteen years. In 2011, women held 16% of permanent positions; by 2024 this had risen to nearly 38%. While this marks substantial progress, balanced representation has not yet been achieved.

Progress differs across career stages. The proportion of women among PhD candidates and postdoctoral researchers has increased significantly, but representation at senior levels remains lower. Sustained attention to recruitment, promotion and retention is therefore essential.

Creating an inclusive organisation requires more than hiring practices alone. It means fostering a culture in which everyone feels respected, supported and able to contribute fully. Together with ASTRON and SRON, NOVA participates in the Netherlands Astronomy Equity and Inclusion Committee (NAEIC). Through a shared Code of Conduct and community initiatives, NAEIC promotes accountability, dialogue and mutual respect across Dutch astronomy.

Strengthening diversity and inclusion is central to the vitality of our field. A broad range of perspectives enhances creativity and improves the quality of our research. While progress is evident, building a truly representative and inclusive community remains an ongoing commitment.

NOVA Staff: Gender Distribution

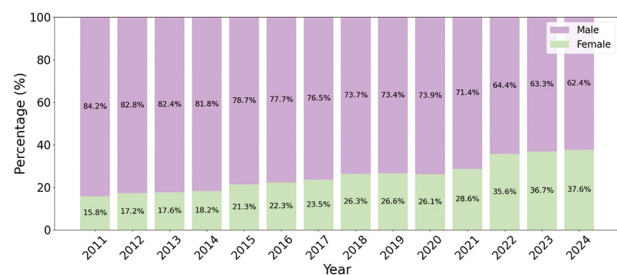

Gender distribution of the NOVA community (four institutes, NOVA groups and the NOVA office), 2011–2024.

NOVA Staff: Career Level

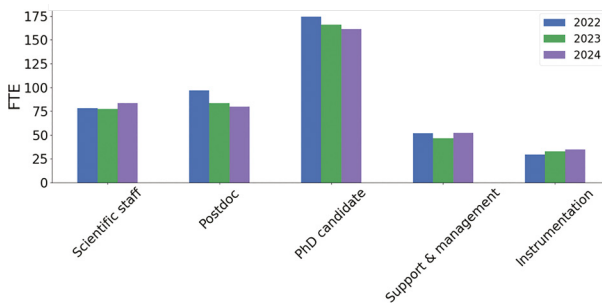

Full-time equivalent (FTE) positions by role, 2022–2024.

NOVA Staff: Location

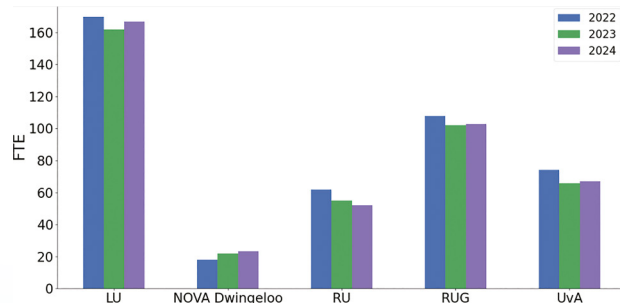

Full-time equivalent (FTE) positions by institute, 2022–2024.



Agnes van Hoof

Can you tell us about your most recent discovery or a recent development you are excited about?

My PhD is on fast X-ray transients (FXTs), which are bursts of X-ray photons lasting from hundreds to thousands of seconds and originate from explosive, extragalactic events. While much is known about other transient types (e.g. gamma-ray bursts (GRBs) or fast radio bursts (FRBs)), our understanding of these FXTs remains poor. In our group, we work on follow-ups of these events, detected by the Einstein Probe (EP) satellite, in multi-wavelength, especially optical and near-infrared. My first paper, that I recently submitted is about the event EP240801a, which is an FXT but also a GRB, suggesting a similar origin for (at least) some of these two transient types. In Hubble and James Webb data, we found evidence for a broad-lined Type Ic supernova (SN), proving that this FXT was caused by the collapse of a massive star in another galaxy at redshift $z=1.67$. It is also the furthest spectroscopically confirmed GRB-SN to date!

How do you experience being an astronomer in the Netherlands and being part of NOVA?

It is always very useful to extend your network and get to know astronomers from different institutes working on similar topics or even astronomers from other fields; you can learn a lot from them! Another focus of our group is on the host galaxies of FXTs, and during one of the NOVA meetings I spoke with people who work on FRBs, and I found out that they do similar research on host galaxies and that we can learn from each other. These meetings that NOVA organizes are a very good way to get in contact with others and extend your knowledge of astronomy in general.

What do you hope to achieve in your professional work over the next year, and what role could NOVA play?

I hope that we can unravel the origin of many more FXTs and that we can start drawing more general conclusions about their progenitors in the coming years. For that, we need many observations from many good telescopes. NOVA plays a big role in developing instruments for many telescopes, such as WEAVE, BlackGEM, and the ELT, which is going to play a very important role in discovering optical counterparts of FXTs in the future. The instruments that NOVA builds are therefore very important for my research.

Also, keep discussing our work during national meetings with researchers from outside our own field will hopefully enlighten us and help us to find the answers to the questions that we have.

If you could share one message about astronomy with the general public, what would it be?

Astronomy is not just about solving difficult equations and the potential applications it might bring us. Astronomy is ultimately about curiosity; everybody looks up to the stars and asks themselves questions, not just to understand distant galaxies or fast X-ray transients that happened thousands of years ago, but also about understanding our own place within the universe. I think it's important for people to know that every discovery is a step towards answering the questions that humanity has had throughout history. You don't need to be a professional astronomer to appreciate that sense of wonder; simply looking up at the stars and appreciating the view makes you part of it.

NOVA Organization

Board

Prof.dr. H.J.A. Röttgering		UL	until 15/08/2022
Prof.dr. I. Snellen		UL	from 16/08/2022
Prof.dr. C. Dominik	<i>chair</i>	UvA	
Prof.dr. J. Hörandel		RU	
Prof.dr. L.V.E. Koopmans		RuG	

NOVA Directorate & Office

Prof.dr. A. Helmi	<i>Scientific Director</i>		until 31/08/2023
Prof.dr. S.C. Trager	<i>Scientific Director</i>		from 01/09/2023
Prof.dr. G.A. Nelemans	<i>Deputy Scientific Director</i>		until 31/05/2024
Prof.dr. P.G. Jonker	<i>Deputy Scientific Director</i>		from 01/06/2024
Dr.ir. M. Rodenhuis	<i>Executive Director</i>		
Dr. T.P.G. Wijnen	<i>Instrumentation coordinator</i>		
F. van Brenk	<i>Controller</i>		until 30/11/2024
M.E. Jaworska	<i>Controller</i>		from 11/11/2024
H. Olgun	<i>Administrator</i>		
J.C. Liesting	<i>Management assistant</i>		from 15/02/2022

Supervisory Board

Prof.dr. J. Knoester		UL	
Prof.dr. P.H. van Tienderen		UvA	
Prof.dr. S.J. de Jong		RU	

Prof.dr. R.G.E. Timmermans	RuG	until 30/06/2022
Prof.dr. J. Frenken	RuG	from 01/07/2022

International Board

Prof.dr. D.N. Spergel	<i>chair</i>	Princeton University and Flatiron Institute, USA
Prof.dr. W. Benz		Universität Bern, Switzerland
Prof.dr. R.L. Davies		University of Oxford, UK
Prof.dr. V.M. Kaspi		McGill University, Canada
Prof.dr. B.P. Schmidt		Australian National University, Australia
Dr. L.J. Tacconi		Max Planck Institute for Extraterrestrial Physics, Germany
Dr. E. Choquet		Laboratoire d'Astrophysique de Marseille, France
Ms. C. Stindt	<i>PhD student member</i>	Stratingh Institute, University of Groningen, NL
Dr. M. de Jong	<i>industry member</i>	McKinsey & Company, NL

Instrument Steering Committee

Prof.dr. G. Wright	<i>chair</i>	UK — ATC
Dr. T. Herbst		MPIA, Heidelberg
Dr. A.G.A. Brown		UL
Dr. J.M.L.B. Désert		UvA
Dr. T. Augusteijn		NOT, La Palma
Prof.dr. A. Levan		RU
Dr. F. Snik		UL
Dr. G.A. Verdoes Kleijn		RuG
Dr. F. Helmich		SRON/KNMI

Dr. I.M. van Bommel	JIVE
Dr. F. Kemper	ESO
Dr. W. Jellema	SRON/RuG
Dr. P.G. Roelfsema	SRON
Prof.dr. R.A.D. Wijnands	UvA

NOVA Information Center (NIC)

M. Baan MSc	<i>Head of the NIC</i>
D. Redeker MSc	<i>Press and information officer</i>
Dr. J. Holt	<i>Education Manager</i>
J. Hanse	<i>Planetarium officer</i>

Minnaert Committee

Dr. J. Vink	<i>chair</i>	UvA	
Prof.dr. Reynier Peletier		RuG	
Prof.dr. I. Snellen		UL	until 16/08/2022
Dr.ir. F. Snik		UL	from 17/08/2022
Dr. M. Klein Wolt		RU	
Drs. Marieke Baan		NOVA NIC (ex officio)	
Dr.ir. M. Rodenhuis	<i>observer</i>	NOVA	
Dr. M. Min		SRON	
Dr. H. K. Vedantham		ASTRON	
Claudia van Oostrum		SRON (ex officio)	
Frank Nuijens		ASTRON (ex officio)	



Ziggy Pleunis

Can you tell us about your most recent discovery or a recent development you are excited about?

I want to figure out the origin of the mysterious extragalactic radio flashes of millisecond duration that we call fast radio bursts (FRBs). We have made great progress in recent years by detecting the first large sample of FRBs (thousands of them), and now I am very excited about the upgrade of the current world's best FRB detector, the CHIME telescope, with three smaller versions of the same telescope spaced thousands of kilometers apart. By catching the same FRBs with all four telescopes, we can pinpoint their locations within their host galaxies, seeing exactly where they are produced.

How do you experience being an astronomer in the Netherlands and being part of NOVA?

To fully capture and understand phenomena such as FRBs, one really needs to bring together expertise across a wide range of topics in instrumentation, observation, and astrophysics. The strength of NOVA is that it includes world experts in essentially all major fields of astronomy within the close-knit astronomy community in the Netherlands, and I really enjoy how easy it is to interact and work with my colleagues at the other Dutch institutes.

What do you hope to achieve in your professional work over the next year, and what role could NOVA play?

Besides providing a compelling mystery to solve, FRBs are also unique probes of the universe at large because their radio signals hold a record of all interactions with the magnetized plasma they have traveled through. Using this information, we can help solve some major outstanding questions related to how galaxies form and evolve by studying FRBs. For the next year, I am excited to start collaborating with the galaxy formation experts within NOVA, to make FRBs the best possible astrophysical tools.

If you could share one message about astronomy with the general public, what would it be?

Studying astrophysical mysteries helps us to understand our own place in the universe. At the same time, because seeing further requires pushing the boundaries of what's possible with technology, our research also drives innovation.

04

NOVA
Networks



Network 1: Formation and evolution of galaxies: from high redshift to the present

NOVA Network 1 (NW1) focuses on the study of galaxy formation and evolution, from early cosmic time to the present day, and the general cosmological context. It comprises the study of ordinary (baryonic) matter, as well as dark matter and dark energy, and how these three ingredients gave rise to the formation of large-scale structure, shaping the Universe that we see today. The core of NW1 tackles main fundamental questions in the field, such as: *when and how did the first galaxies form and which of them had the main role in the process of hydrogen Reionisation?; How have these sources evolved to form present-day galaxies like our own Milky Way?; and what are the natures of dark matter and dark energy?*

For NOVA NW1, the 2022–2024 period has been mainly defined by the start of the James Webb Space Telescope’s scientific operations, as well as the Euclid Space Telescope’s launch. At the same time, the new, NOVA-led multi-object spectrograph WEAVE (PI S. Trager) on the William Herschel Telescope in La Palma has seen first light [1]. These instruments, jointly with other continuing ground – and space-based facilities, such as the VLT, ALMA, LOFAR, and Gaia, provide the necessary data for NW1 to address fundamental questions in the field. At the same time, continuous advances in state-of-the-art cosmological simulations set the framework for the interpretation of new results in a global context. In the following we present some of the main highlights of NW1 research in 2022–2024.

Sharper and farther than ever before: the early Universe seen by JWST

Our knowledge of the high-redshift (high- z) Universe has been revolutionised in the past few years thanks to the unprecedented sensitivity and angular resolution

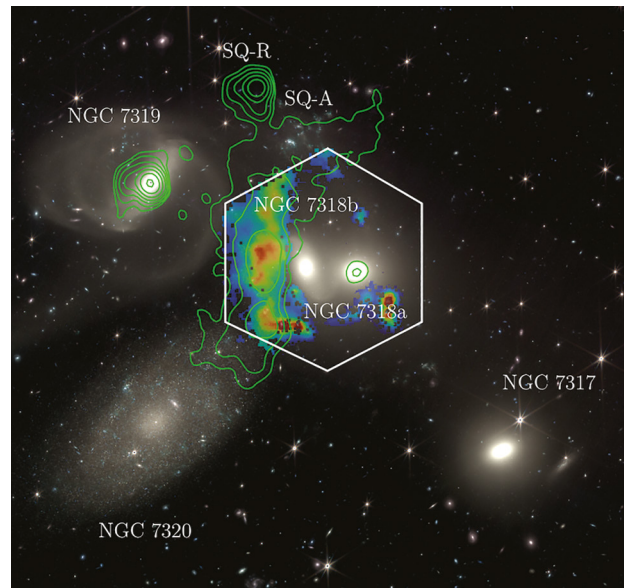

JWST composite image of the Stephan’s Quintet with the field observed with WEAVE at first light delimited with a white hexagon. The green contours indicate LOFAR radio flux densities. WEAVE’s first light data, when combined with LOFAR 144 MHz radio data and JWST NIRSpec and MIRI data, show that the shocking of the cold gas phase is hypersonic. In contrast, the shock is relatively weak in the hot plasma visible in X-rays, making it inefficient at producing the relativistic particles needed to explain the observed synchrotron emission. Figure taken from ref. [1].

of specific spectral emission lines which, for the first time, can be observed in distant galaxies.

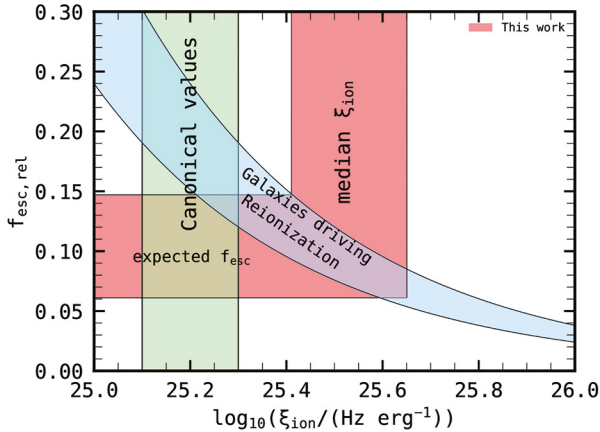

Escape fraction (y axis) vs. photon-production efficiency (x axis), with the combination of values necessary for cosmic reionisation indicated (blue band). The canonical values of the photon-production efficiency considered before JWST (green band) required too high an escape fraction and could not explain the process of reionisation. The new photon-production efficiencies measured on JWST galaxies (red bands) indicate that much lower and realistic escape fractions are sufficient for reionisation. Figure taken from ref. [5].

Pushing the frontier of galaxy evolution at Cosmic Dawn

Understanding the earliest phases of galaxy formation requires sensitive measurements of the dust, gas, and metal content of galaxies during the epoch of reionisation. The REBELS (Reionisation Era Bright Emission Line Survey) ALMA Large Program, led by Bouwens, has delivered major breakthroughs in this area during the 2022–2024 period. Designed to obtain systematic measurements of dust-continuum emission and far-infrared cooling lines in UV-bright galaxies at $z \gtrsim 6.5$, REBELS provides the first statistically meaningful view of obscured star formation and interstellar-medium (ISM) conditions for massive galaxies in the young Universe.

Caputi’s research group has been at the forefront of this field with important new results. Postdoc Kokorev led the most comprehensive census of the so-called ‘Little Red Dots’ [2], a newly discovered population of compact sources characterised by being blue at rest-frame UV wavelengths, while being red at rest-frame optical wavelengths. The vast majority of these sources (if not all) are known to host a broad-line AGN [3].

In parallel, PhD student Rinaldi detected for the first time H emission in individual galaxies at $z > 7$ [4] and different works led by Caputi and Rinaldi, respectively, investigated the importance of line-emitting galaxies and non-emitters as sources of Reionization [5, 6]. These works concluded that all low-stellar-mass galaxies at those redshifts must have had stochastic episodes of star formation with high photon production efficiencies that allowed them to reionise their surrounding medium. These latter studies have been the product of the scientific exploitation of the JWST Mid Infrared Instrument (MIRI) European Guaranteed Time data. NOVA has had priority access to these data thanks to its technical contribution to MIRI, both in contributing to building the instrument and in the data reduction pipeline development.

A decisive step forward came with the REBELS pilot analysis [7], led by PhD student Schouws (supervised by Bouwens and Hodge), which demonstrated ALMA’s ability to spectroscopically confirm and characterise luminous galaxies deep into the reionisation era. This work established the observational and analysis framework that underpins the full survey. Building on this, the REBELS survey overview paper [8], led by Bouwens, presented a comprehensive census of dust and line emission across the entire REBELS sample. The resulting dataset—currently the largest homogeneous collection of ALMA measurements obtained during reionisation—has enabled precise constraints on obscured star-formation rates and ISM conditions in early massive galaxies, opening a new observational window onto galaxy assembly at cosmic dawn.

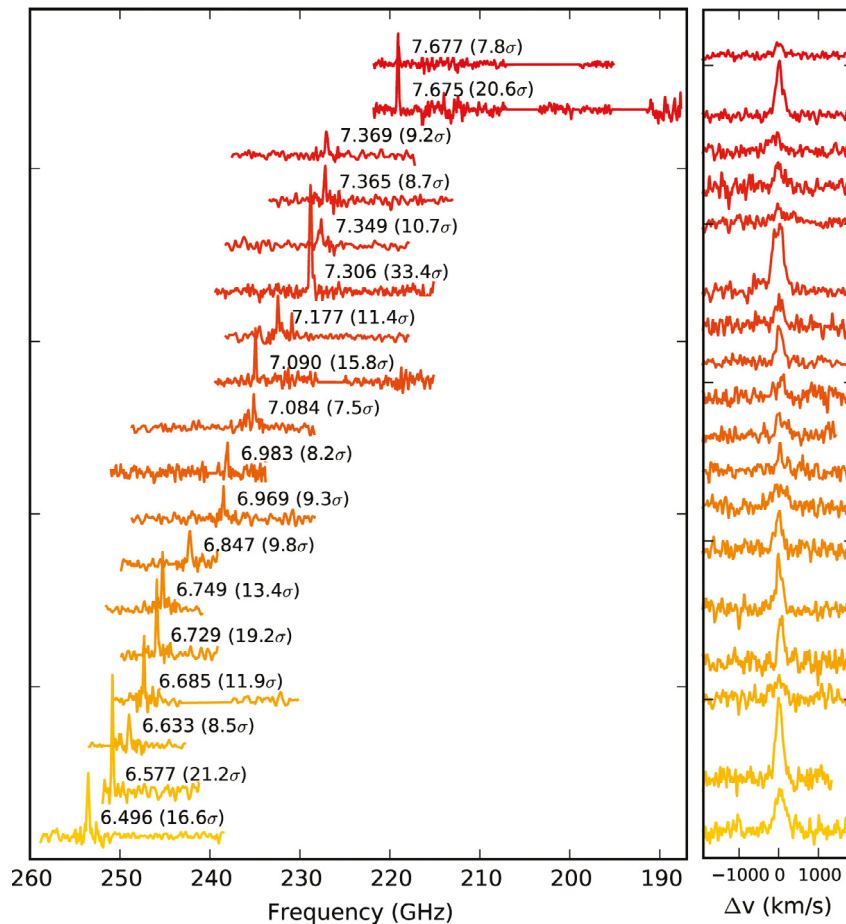

Left: Illustration of some of the high-significance ISM-cooling lines identified in the REBELS ALMA Large Program and the spectral scans used to locate these lines. Shown on the figure next to the [CII]158 μ m line detections are the systemic redshifts of the sources as well as an estimate of the significance of the line detection. Right: Velocity structure of the same line detections as shown in the left panel. The REBELS results (+pilot studies) demonstrate ALMA's efficiency as a "redshift machine" in the epoch of reionization. Figure taken from ref. [8].

ALMA reveals regular rotation and dark matter in galaxies near and far

Studying gas dynamics in distant galaxies is crucial to understand the properties of their interstellar media and the conditions for new star formation. The capabilities of the ALMA interferometer are unique for these kinds of studies. The research group led by Fraternali analyses and interprets ALMA data for nearby and distant galaxies. In a study led by PhD student Roman-Oliveira [9], they analysed the [CII]

rotation curves of five galaxies at redshift $z = 4-5$. They found clear evidence of regularly rotating discs with flat rotation curves, reaching maximum velocities between 200 and 560 km/s. Surprisingly, the galaxies display high ratios of ordered-to-random motion, indicating that dynamically cold, rotation-supported discs were already in place at this early epoch.

In another work PhD student Mancera-Piña [10] led a study of ultra-diffuse galaxies (UDGs), which are unusual systems with the stellar mass of dwarfs but light profiles resembling massive spirals like the Milky Way. Their formation mechanisms remain debated. Some of these UDGs have been found to be gas rich and isolated, showing unusually extended HI reservoirs that are distributed in regularly rotating discs. For one of these galaxies, the dark matter content could be

inferred via decomposition of the HI rotation curve. Surprisingly, the observed rotation appears consistent with the baryons alone, with little room for dark matter, while a standard cold dark matter (CDM) halo overestimates the rotational speed by a large margin. Follow-up work confirms this dark matter deficiency, challenging current galaxy formation models and offering clues to the nature of dark matter.

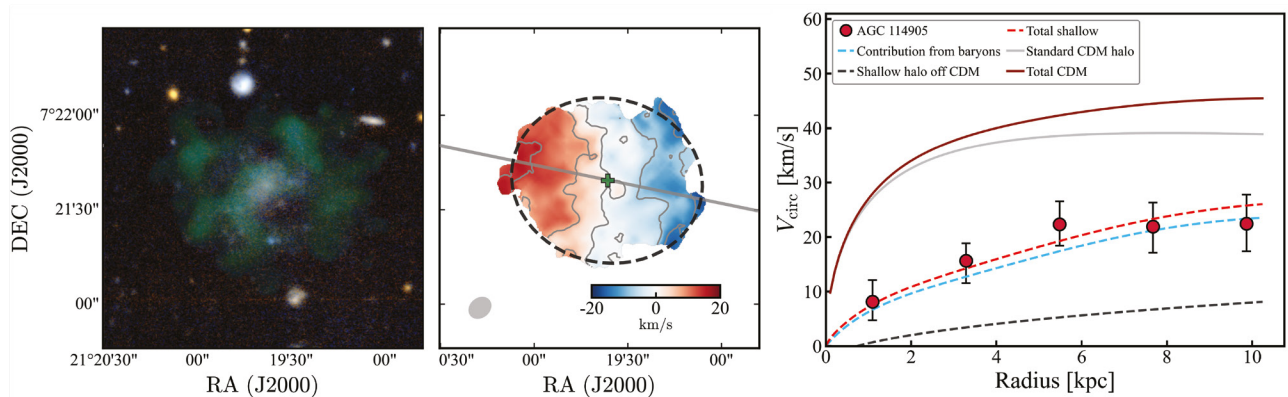

Left: optical image of an UDG AGC 114905. Middle: HI velocity maps. Right: circular velocity derived from the HI maps versus distance from the centre. This figure shows that the velocity profile can be well modelled with baryonic matter components, without any need for dark matter.

Gaia continues to uncover the history and structure of the Milky Way

The Gaia mission is providing many details on the dynamical complexity of our Galaxy, now and in the past. Helmi's research group has analysed the Third Data Release of Gaia (Gaia DR3) and combined these data with other photometric and spectroscopic data to gain new insights into our Milky Way, often by using cutting-edge data science techniques. In a study led by PhD student Dodd [11], the group applied a single-linking clustering algorithm to 3D positions and 3D velocities, and further combined these results with spectroscopic metallicities to unravel the Galaxy's merger history from fully phased-mixed stars.

However, the picture of the Milky Way history becomes very incomplete at early times. A local, highly detailed,

analysis of our very early Galaxy can unveil the physics of the first stars, their enrichment, and the very early assembly of galaxies in the epoch of reionization — highly complementary to the extremely high-redshift observations, as it probes much smaller scales. The scarcity of well-studied stars from the earliest generations in different environments, represented by the lowest-metallicity stars, limits us severely when attempting to study the era of the first stars and early Galaxy assembly. Next-generation massively-multiplexed instruments will soon complement Gaia astrometry to its faint limit with crucial radial velocities and chemical abundance patterns. Specifically, the Northern WEAVE and Southern 4MOST surveys will finally provide much-needed high-priority targeting of

the most metal-poor stars in low- and high-resolution. Starkenburg and her group have pioneered methods to efficiently find the metal-poor stars likely to be the earliest stars formed in the Milky Way using a narrow-band filter around the Ca H&K absorption lines (as in, e.g., the Pristine survey). Recently, these catalogues have been augmented with the use of the shallower but all-sky Gaia spectrophotometry analysed using the same technique in work co-led by Starkenburg and collaborator Martin from Strasbourg Observatory [12]. These datasets prepare us for the next revolution with 4MOST and WEAVE, as they ensure that these rare early-generation stars are targeted in those upcoming surveys.

In the more well-studied metal-poor Galactic halo, more exciting discoveries certainly await. A recent highlight has been the discovery of C-19 by a group including Starkenburg [13], a disrupted globular cluster well below the theoretical “metallicity floor”. C-19 has $[Fe/H] = -3.4$, whereas it has been previously argued no globular clusters could be formed below $[Fe/H] = -2.5$. This is an important piece of the puzzle to understand the early Universe, as it uncovers a mode of star formation for extremely metal-poor stars that was previously deemed impossible. It is unclear how many more of such objects can still be hiding in the outskirts of our Milky Way.

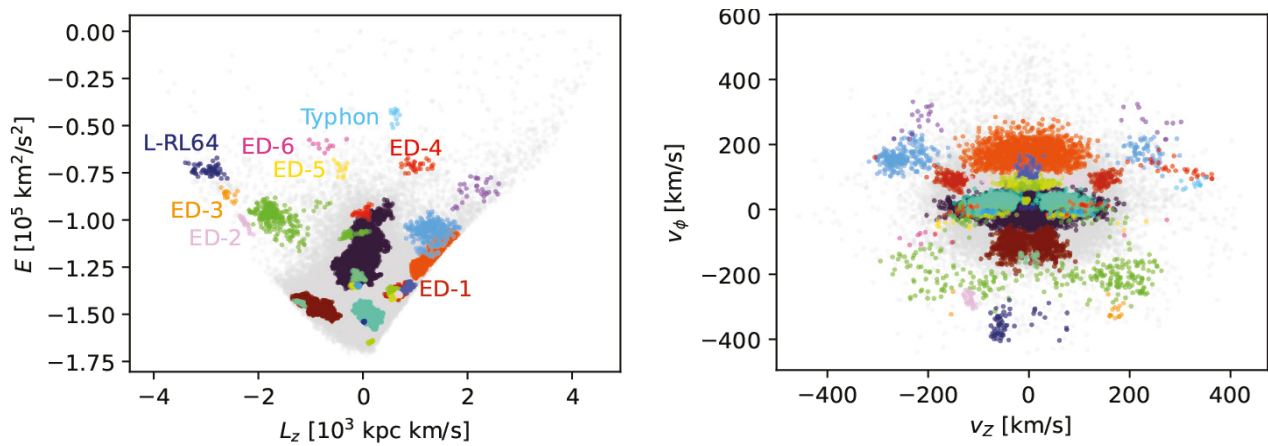

Groups of accreted debris in the Milky Way’s halo determined from Gaia DR3 positions and velocities uncovered through a machine-learning algorithm. The algorithm found 27 independent groups and clusters in our Galaxy’s outskirts, showing the wealth of substructure accreted by the Milky Way even in our local neighborhood. Left: stellar orbital energy as a function of angular momentum (from the integral of motion space projection). Right: rotational velocity as a function of velocity perpendicular to the Galactic plane. Figure adapted from ref. [11].

Probing dark matter with cosmological surveys

Weak gravitational lensing, the coherent patterns in the shapes of galaxies introduced by the warping of space-time by intervening clumps of dark matter, is a powerful probe to map the distribution of dark matter in the Universe. It is a key driver for the ESA Euclid mission and the prime objective of the Kilo-Degree Survey (KiDS). PhD student Li, who worked under the supervision of Kuijken and Hoekstra, published a leading article with updated cosmological parameter constraints using data from the fourth KiDS

data release, covering about 1000 square degrees [14]. The main improvement over previous analyses was the use of better measurements of galaxy shapes, taking advantage of a suite of tailored multi-band image simulations that were used to calibrate observational systematics. Also small enhancements in the modelling of the lensing signal were incorporated. This analysis confirmed that the derived values of the cosmological parameters are in tension with those previously derived from Planck’s cosmic microwave background data.

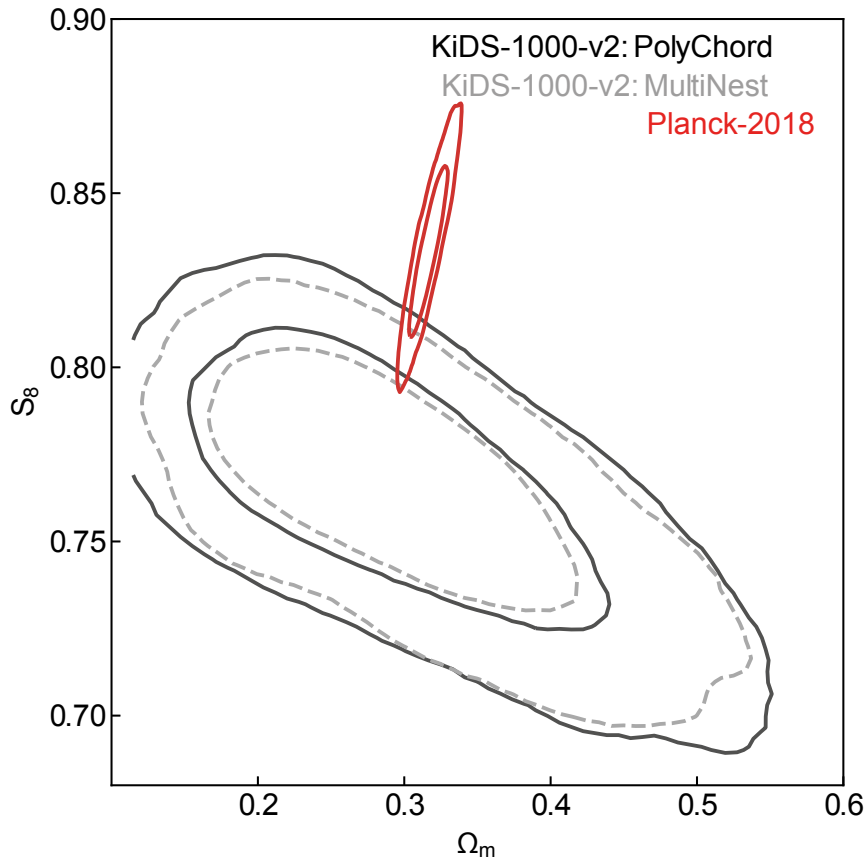

Constraints on S_8 versus Ω_m obtained from the KiDS galaxy survey (black contours). The independent constraints derived from Planck data (red contours) are also shown. The small intersecting area between both sets of contours indicates that the derived cosmological parameter values are in tension with each other. Figure taken from ref. [14].

New advances in cosmological simulations

Observational cosmology based on measurements of the growth of large-scale structure is increasingly limited by the accuracy of theoretical predictions. The redistribution of gas relative to dark matter due to feedback processes associated with galaxy evolution is particularly uncertain and becomes increasingly important as observations target smaller scales. Hydrodynamical simulations can in principle help resolve this issue, but they tend to have volumes that are too small, they do not reproduce the relevant observables and/or they do not include model variations that cover the relevant parameter space.

NOVA astronomers have also been at the forefront of cosmological simulation developments. Schaye and his group developed the FLAMINGO suite of simulations for cosmology and galaxy cluster physics to address the mentioned shortcomings [15]. To ensure that the simulations are sufficiently realistic, the prescriptions for stellar and AGN feedback are calibrated to the observed low-redshift galaxy stellar mass function and cluster gas fractions. The calibration is performed using machine learning, separately for each of FLAMINGO's three numerical resolutions, as presented in the paper led by PhD student Kogel [16]. This novel approach

enables specification of the model by the observables to which they are calibrated.

The simulations of the FLAMINGO suite have been run with the code package SWIFT, developed by Schaller and collaborators [17]. This is an open-source code which is highly-parallel, versatile, and modular, and is at the same time coupled with hydrodynamics, gravity, cosmology, and ingredients of galaxy-formation physics.

The FLAMINGO suite includes both simulation variations at fixed cosmology and different cosmologies, including different neutrino masses, all in boxes of 1 Gpc on a side. In turn, the astrophysics variations include shifts in the observables to which the model is calibrated, and two alternative implementations of AGN feedback. The largest simulation follows a volume of 2.8 Gpc on a side using 3×10^{11} particles, making it the largest ever hydrodynamical simulation run to $z = 0$.

References:

- [1] Arnaudova, M. I. et al., 2024, MNRAS 535, 2269
- [2] Kokorev, V. et al., 2024, ApJ 968, 38
- [3] Kokorev, V. et al., 2023, ApJ 957, L7
- [4] Rinaldi, P. et al., 2023, ApJ 952, 143
- [5] Rinaldi, P. et al., 2024, ApJ 969, 12
- [6] Caputi, K. I. et al., 2024, ApJ 969, 159
- [7] Schouws, S. et al. 2023, ApJ 954, 103
- [8] Bouwens, R. et al. 2022, ApJ 931, 160
- [9] Roman-Oliveira, F. et al., 2023, MNRAS 521, 1045
- [10] Mancera-Piña, P. et al., 2022, MNRAS 512, 3230
- [11] Dodd, E. et al., 2023, A&A 670, L2
- [12] Martin, N. F. et al., 2024, A&A 692, A115
- [13] Martin, N.F. et al., 2022, Nature 601, 45
- [14] Li, S.-S et al., 2023, A&A 679, A133
- [15] Schaye, J. et al., 2023, MNRAS 526, 4978
- [16] Kogel, R. et al., 2023, MNRAS 526, 6103
- [17] Schaller, M. et al., 2024, MNRAS 530, 2378

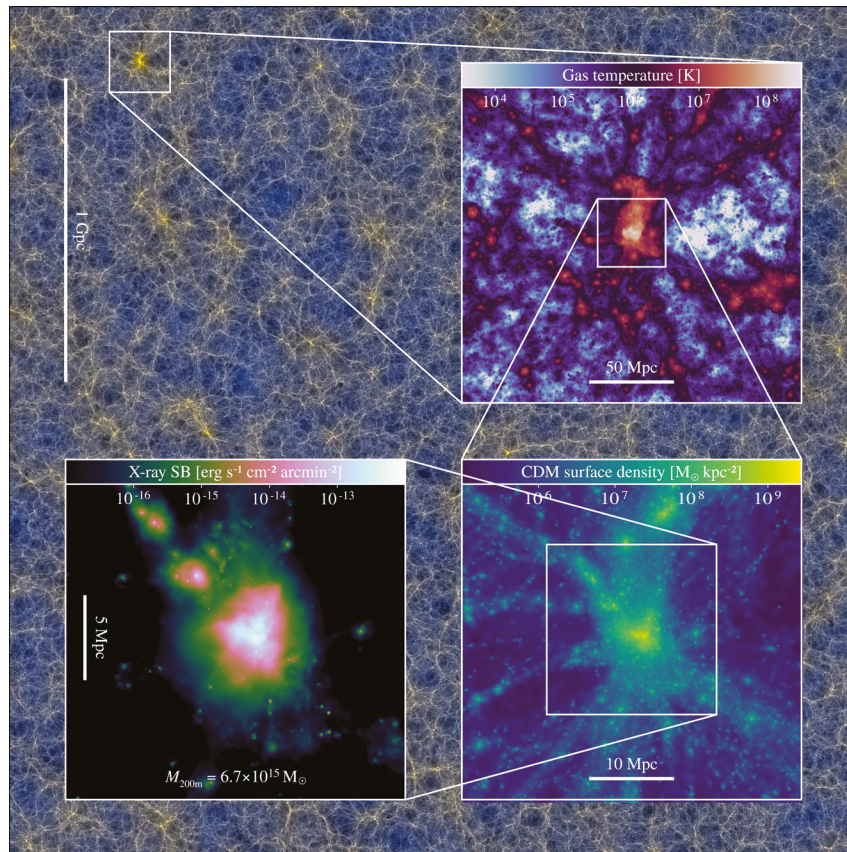

Snapshots of the FLAMINGO simulations, illustrating their high resolving power. Different components at different scales are shown in the insets. From bottom left, anticlockwise: the distributions of X-ray emission in a galaxy intracluster medium; cold-dark-matter distribution around the cluster; map of gas temperature in a region of $\sim 250 \times 250$ Mpc². Figure taken from ref. [15].

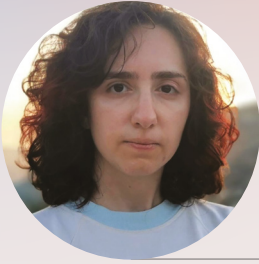

Petra Awad

Can you tell us about your most recent discovery or a recent development you are excited about?

I am excited to have supervised a student during Leiden's summer research program where we mapped the flow of matter within and around cosmic filaments, going beyond the linear regime of the universe's expansion. We used the suite of IllustrisTNG simulations and looked for correlations relating components of the cosmic velocity field (e.g. divergence and curl) to how halos accumulate their mass. This is an idea that I have been interested in for a while now, and I'm happy to have finally had the chance to put it into action.

How do you experience being an astronomer in the Netherlands and being part of NOVA?

I have been very fortunate to have been part of two of the NOVA institutes: I have done my PhD at the University of Groningen and afterwards, I joined Leiden University to work within the Euclid Consortium. I have felt grateful to be part of these universities in the Netherlands and to connect with the other institutes of NOVA, as I realized that I'm gaining the opportunities and skills necessary to conduct research that competes on international levels, and I hope to keep the professional and friendly connections I have made throughout.

What do you hope to achieve in your professional work over the next year, and what role could NOVA play?

My current focus is on the Euclid mission, and my plan is to include several contributions to its image reduction pipeline to further improve the forthcoming data releases. On the science front, I hope to publish the work we have done this summer on the cosmic matter flows within the large-scale structure, and to extract as much information as possible from the prodigious Euclid dataset about the dependence of galaxies' properties on their cosmic environments. NOVA's support would be invaluable in enabling these contributions through close collaborations with its community.

If you could share one message about astronomy with the general public, what would it be?

Astronomy is a science in the same way as other scientific domains are, in the sense that it involves the practice of gaining further knowledge about the universe through observation, testing, and analysis. Additionally, it is an incredibly humbling science, as one examines up close the immensity and beauty of astronomical objects, which ultimately relate to our place in the universe. Therefore, I encourage everyone, including people from underrepresented countries in astronomy such as the one I am from, to learn more about what they see in the night sky.

Network 2: Formation and evolution of stars and planetary systems

Understanding the formation of stars and planets is fundamental to fathoming the rich diversity in exoplanetary systems we see today and to uncovering the history of our solar system, and, by extension, our own origins. NOVA Network 2 researchers use a rich suite of astronomical instrumentation, computational methods and laboratory experiments to study the physical and chemical processes involved. These

studies cover a wide range of topics, such as the birth environment of stellar systems (dominated by the most massive stars present), the physical and chemical processes driving the evolution of planet-forming disks and the assembly of planets and their atmospheres, and the chemistry and microphysics of molecules and small particles. They connect these findings to our Solar System, putting Earth and its inhabitants in context.

Formation and evolution of massive stars

Massive stars shooting out of R136

Feedback from massive stars strongly impacts their local environment and plays a crucial role in galaxy evolution. A NOVA-team led by Stoop, de Koter, and Kaper, used Gaia data to search for massive runaway stars from the young cluster R136 in the Large Magellanic Cloud. This revealed two channels of dynamically ejected runaways, one related to the birth of R136 and one to a cluster interaction. About one-third of the most luminous stars initially born in R136 are runaways, considerably more than theorized. Consequently, their role in shaping and heating the interstellar medium and in driving galactic outflows is far more important than previously thought [1].

Characterizing the birth properties of massive stars

For massive stars, the outcome of formation is rarely observed because the processes involved unfold deep down in highly opaque molecular clouds. Using VLT/X-shooter, PhD student Backs (under supervision of de Koter and Kaper) characterized the population of highly reddened stars in the very young (0.4 Myr) massive star-forming region M17 and, for the first time, identified the empirical location of the zero-age main-sequence (ZAMS) for stars with masses between 10 and 50 M_{\odot} . The ZAMS rotation rates for intermediate-mass

stars (3–7 M_{\odot}) in the region are twice as high as for massive stars, suggesting that the angular momentum gain processes differ between the two groups [2].



Artist's impression of massive stars running away from the young massive star cluster R136 in the Large Magellanic Cloud. In total, 55 such massive runaway stars were identified, considerably more than theorized.

Understanding how planets form

Ices in cold pre-collapse regions

Life's key elements, C, H, O, N, and S, are incorporated into planets via icy dust grains in protoplanetary disks. These ices form initially in the cold, molecular clouds from which star systems collapse. The JWST Early Release Science team Ice Age, led by McClure with a strong NOVA contingent, used NIRCam, NIRSpec, and MIRI spectra to measure ices in the coldest pre-collapse regions. They detected complex organics, including ethanol, and identified sulfur-bearing ices for the first time in the ice elemental budget. These results demonstrated that prebiotic chemistry can begin early and revealed that much of the sulfur, carbon, and oxygen reside in less-volatile refractory species likely to survive infall into the planetary nurseries within disks [3].



JWST NIRCam image of the central region of the Chamaeleon I molecular cloud, highlighting cold, icy cloud material (blue, center) illuminated in the infrared by the glow of the young, outflowing protostar Ced 110 IRS 4 (orange, upper left). The light from numerous background stars, seen as orange dots behind the cloud, can be used to detect ices in the cloud, which absorb the starlight passing through them. Image credit: NASA, ESA, CSA; Science: IceAge ERS Team, Fengwu Sun (Steward Observatory), Zak Smith (The Open University); Image Processing: Mahdi Zamani (ESA/Webb)

Complex organic molecules in protostellar ices

The origin of complex organic molecules (COMs) — widely observed as gases in star-forming regions — is a long-standing puzzle in astrochemistry. Using the unprecedented spectral resolution and sensitivity of MIRI, an international team led by Rocha, van Dishoeck and Linnartz has detected several COMs in protostellar ices. Identification was made possible thanks to dedicated laboratory experiments in Leiden. These detections confirm that COMs are formed mostly on

grain surfaces rather than by gas-phase reactions. It also implies that COMs may be transported efficiently as ices into disks where they can become part of prebiotic material for making habitable planets [4].

Disks around very low mass stars are carbon rich

Most of the rocky exoplanets detected to-date are hosted by Very Low Mass Stars (VLMS), which are the most abundant stars in our galaxy. Recent NOVA-led work by Arabhavi, Tabone, Kanwar, together with Kamp, van Dishoeck and Waters, analysing JWST/MIRI mid-IR spectra of VLMS shows that the disks around these stars are full of small hydrocarbons. Subsequent chemical modeling confirms that the gas in the inner astronomical unit around these stars is carbon-rich ($C/O > 1$) and that these hydrocarbons can efficiently form through gas phase chemistry. This is in stark contrast to the disks around solar-type stars, which are predominantly oxygen-rich. This difference can have important implications for rocky planets forming around these different types of stars [5, 6, 7].

How massive are HAeBe disks?

Many of the best-studied planet-forming disks surround stars of $1.5\text{--}8 M_{\odot}$, the so-called Herbig disks. Using archival ALMA data, a team led by Stapper, Hogerheijde and van Dishoeck for the first time studied how much raw material to build planets is available in these Herbig disks. Compared to T Tauri disks around stars of less than $1.5 M_{\odot}$, Herbig disks are on average 3–7 times as massive. Surprisingly, individual Herbig disks can contain just as much or as little mass as a T Tauri disk, but massive Herbig disks are much more common than massive T Tauri disks [8].

Free-free emission from an ionized jet

Protoplanetary disks around young stars have often shown presence of free-free emission at radio wavelengths, without a clear indicator of its physical origin. A NOVA-team led by PhD student Rota (under the supervision of van der Marel) has demonstrated that this free-free emission likely originates from an ionized jet, and is tightly connected with the accretion rate of the material falling onto the star. Using multi-wavelength analysis of high-resolution ALMA data of a sample of disks with inner cavities, the team could disentangle the free-free emission of the inner regions from the dusty outer disk. The discovery has opened up a new possibility to study jets and angular momentum transport in protoplanetary disks, with promising potential for ngVLA and SKA [9].

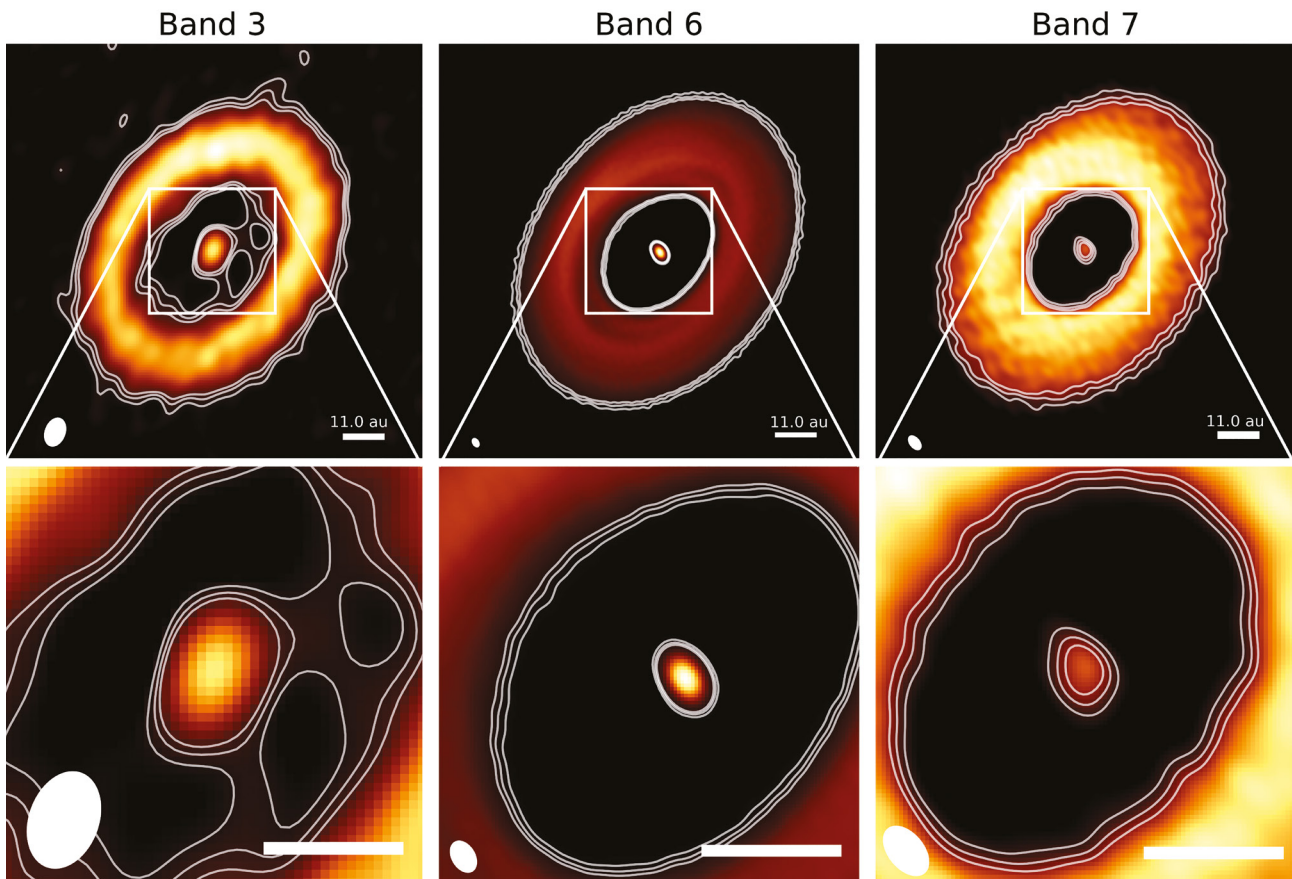

Intensity map of the disk around HD100546 in different ALMA bands (top panels). These images help identify the onset location of an ionized jet from this system. Bottom panels show zoom-ins of the top panels.

Exotic worlds

Collision of two ice-giant exoplanets

Kenworthy and coauthors had unexpected help from social media when an amateur astronomer pointed out that the star they looked at, ASASSN-21qj, became twice as bright in the infra-red some two years before a complex optical eclipse. The best explanation was that they were seeing the collision of two ice-giant exoplanets and the subsequent transit of the expanding debris cloud two years later. The amateur astronomer joined the coauthors in the Nature paper and follow up observations with JWST are being analysed [10].

The atmosphere of a lava world

Lava worlds are exciting rocky exoplanets whose molten surfaces and outgassed atmospheres provide unique insights into the evolution of rocky planets. A NOVA team — van Buchem, Zilinskas and Miguel — led the theoretical interpretation and numerical modelling of JWST data for the lava world 55 Cnc e, resulting in the first detection of an atmosphere on a lava world. The planet hosts a volatile atmosphere likely enriched with heavy species from its magma ocean, overturning previous assumptions that such volatiles would be completely lost. This breakthrough opens new avenues for studying interior-atmosphere interactions on rocky exoplanets [11].

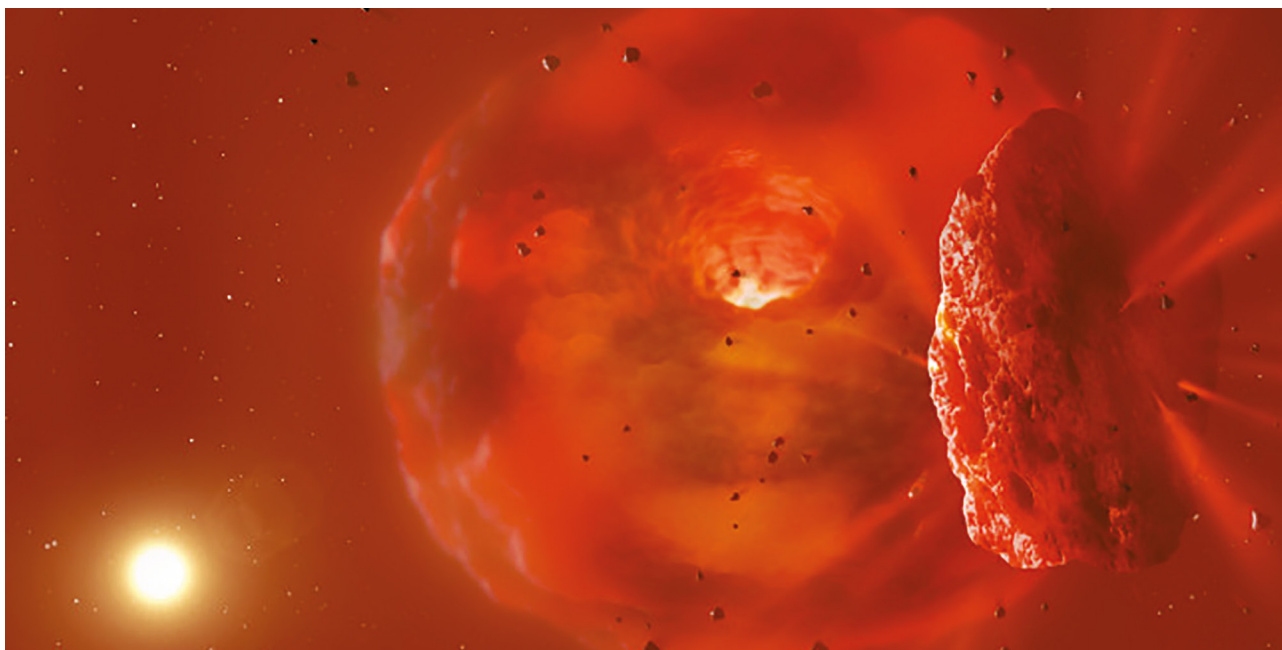

Artist impression of the collision of two ice-giant exoplanets in the system ASASSN-21qj creating a debris cloud that periodically transits in front of the host star.

Chemistry in the Laboratory for Astrophysics

Fragile organic molecules in the lab

Polycyclic Aromatic Hydrocarbons (PAHs) are one of the most important and ubiquitous families of interstellar molecules, locking up to 15% of all cosmic carbon and participating in the chemistry of the interstellar medium (ISM). A NOVA-team led by Sundararajan, Candian, Tielens and Linnartz performed experiments with the I-POP experimental setup at the Laboratory for Astrophysics (Leiden) to study how these molecules behave when they interact with UV photons, mimicking the conditions typical for the interstellar medium. The experimental study together with computational chemistry calculations showed that molecular properties, such as curvature, make the PAHs more fragile and photons can easily break them down into smaller molecules. Interestingly, the products of photon-driven fragmentation are similar, independently of the specific PAH studied [12].

Where has all the cosmic sulphur gone?

In star-forming regions, astronomers have long puzzled over the disappearance of up to 99% of this life-essential element. At the Leiden Laboratory for Astrophysics, interstellar ices made of ammonia and hydrogen sulfide are simulated and analyzed using the NOVA-supported IRASIS setup. These experiments have resulted in the efficient formation of ammonium hydrosulfide (NH_4SH), a salt already found in pristine cometary ice as the main form of sulfur. Its presence is betrayed by a distinct fingerprint that matches a mysterious $6.85 \mu\text{m}$ signal detected by several IR telescopes. These findings suggest NH_4SH is a hidden storehouse of sulfur in space, reshaping our understanding of interstellar chemistry [13].

The solar system

A stellar flyby shaped the outer solar system

Thousands of small bodies beyond Neptune orbit the Sun on eccentric ($e > 0.1$) paths unlike Solar System planets. While giant planet migration in early Solar System history scattered many trans-Neptunian objects (TNOs), it cannot account for the few distant TNOs (perihelion > 60 AU) beyond the planets' reach. Instead, a closer stellar flyby can produce these TNO features, but the encounter parameters are vast. Comparing observed TNOs to thousands of flyby simulations, a team including NOVA researcher Portegies-Zwart found that a flyby by a $0.8 M_{\odot}$ star at 110 ± 10 au and 70° inclination best matches all TNO dynamical groups, including the hard-to-explain retrograde population. Such encounters are common: at least 140 million solar-type stars in the Milky Way have likely experienced one. Therefore, upcoming Vera Rubin telescope observations can be used to test whether distant and retrograde TNOs are frequent [14].

Jupiter's interior

A study led by NOVA researcher Miguel revealed new evidence for Jupiter's inhomogeneous interior, reshaping current understanding of the giant planet's formation and evolution. By combining gravity measurements from NASA's Juno mission with advanced interior models, the work shows that Jupiter's deep interior retains primordial compositional gradients and diluted heavy elements extending far below the visible atmosphere, gradients likely acquired during its formation. This finding challenges the long-standing view of a fully mixed interior and indicates that mixing processes during Jupiter's evolution were far less efficient than previously assumed. The results provide a crucial benchmark for interpreting giant exoplanets and revising processes such as core erosion and double-diffusive convection and how they shape giant planet evolution [15].

Mercury, a world of extremes

While dayside temperatures reach 430 C, radar measurements from Earth and observations by orbiting spacecraft show that the permanently shadowed regions around Mercury's North Pole contain water ice of unknown origin. A team of NOVA researchers led by PhD student Frantseva with Mueller, Van der Tak, and Ten Kate have calculated how many asteroids, comets, and dust particles are impacting Mercury every year. They find that over a billion years, such impacts deliver enough water to explain the radar and spacecraft observations [16].

References:

- [1] Stoop, M. et al., 2024, *Nature* 634, 809
- [2] Backs, F. et al, 2024, *A&A* 690, 113
- [3] McClure, M.K. et al., 2023, *Nature Astronomy*, 7, 431
- [4] Rocha, W. et al., 2024, *A&A* 683, A124
- [5] Tabone, B. et al. 2023, *Nature Astronomy* 7, 805
- [6] Arabhavi, A.M. et al., 2024, *Science* 384, 1086
- [7] Kanwar, J. et al., 2024, *A&A* 689, A231
- [8] Stapper, L. et al., 2022, *A&A* 658, A112
- [9] Rota, A.A. et al., 2024, *A&A*, 684, 134
- [10] Kenworthy, M. et al., 2023, *Nature* 622, 251
- [11] Hu, R. et al., *Nature*, 2024, 630, 609–612
- [12] Sundararajan, P. et al., 2024, *Phys. Chem. Chem. Phys.*, 26, 19332–19348
- [13] Slavicinska, K. et al., 2025, *A&A* 693, A146
- [14] Pfalzner, S. et al., 2024, *Nature Astronomy* 8, 1380
- [15] Miguel, Y. et al., 2022, *A&A* 662, A18
- [16] Frantseva, K. et al, 2022, *Icarus* 383, 114980



Lieke van Son

Can you tell us about your most recent discovery or a recent development you are excited about?

The release of the 4th gravitational-wave catalogue (GWTC-4) last August (2025) has been especially exciting. It revealed new clues about where stellar-mass binary black hole (BBH) mergers come from, including a clear global peak in the BBH mass function at around $9 M_{\odot}$. For the first time, we have enough observations to start examining properties of sub-populations within the global binary black holes population in meaningful detail.

These results help us understand both how massive stars end their lives and how BBH progenitors pair up to form gravitational-wave sources. I'm particularly excited because there's tentative evidence that the 'stable mass transfer' channel (which is one of my favourite formation channels as I study it in detail), may contribute to this peak, matching some of my earlier predictions.

How do you experience being an astronomer in the Netherlands and being part of NOVA?

Even though I have only just started at Radboud this fall (2025), it has already been great joining the Dutch astronomy community and the NOVA network. As part of the Sectorplan Astronomy x Data Science initiative, I'm excited to connect with fellow new hires across the country and help strengthen data-driven collaboration between universities.

What do you hope to achieve in your professional work over the next year, and what role could NOVA play?

I am looking forward to building up my group with new students and postdocs (with support of the NOVA network). As a group, we will investigate the origins of stellar black holes in binaries: both as part of merging black hole binaries and those with living stellar companions. I'm furthermore excited to hear the latest Dutch astro news at the NAC and to become fully embedded in Network 3!

If you could share one message about astronomy with the general public, what would it be?

Did you know that we 'hear' the echo of two black holes crashing into each other, about once every other day?

Network 3: Astrophysics in extreme conditions

The goals of NOVA Network 3 are to understand the extreme conditions that exist in many astrophysical systems and to use these as cosmic probes to better understand the relevant fundamental physics processes, as well as their impact in cosmology and galaxy formation (Network 1) and on star formation and their evolution (Network 2). There has been great progress across a large range of these topics in the 2022–2024 period. Across the electromagnetic spectrum, we have zoomed in on the windows that NOVA astronomers have opened in the previous years, improving our work on black hole shadows, accretion physics and multi-wavelength and multi-messenger transients.

The dynamic radio sky

Amsterdam researchers (de Ruiter, Rowlinson, Wijers) have identified a mystery long-duration radio transient [1]. This discovery is the first follow-up of a mysterious long-duration radio transient (class of now 10 sources). The pulses of ILT J1101+5521 come from a magnetised white dwarf in a 125-min orbit with a brown dwarf, and only when the field lines from the WD that interact with the brown dwarf point straight at us.

The AstroFlash team in Amsterdam and at ASTRON (Hessels, Hewitt, Kirsten, Pleunis, Snelders) localised a repeating FRB source to a globular cluster associated with the M81 galaxy, using the European VLBI Network (EVN) and showed that the FRB originates from a highly magnetised neutron star formed either through the accretion-induced collapse of a white dwarf, or the merger of compact stars in a binary system [2]. Additionally, they detected ultra-fast radio bursts from FRB 20121102A — establishing a population of ultra-fast radio bursts — lasting only microseconds, 1000x shorter than typical FRBs [3].

Using the NOVA NW3 “ARTS” instrument for the radio telescope at Westerbork, The Netherlands, NW3 astronomers discovered two dozen of the unexplained

In the near — to mid-term future we expect these capabilities to further grow with NOVA-leads in BlackGEM, the Africa Millimeter Telescope, and further upgrades to LOFAR. This is combined with significant roles in much larger endeavors. We have started to exploit JWST/MIRI, have joined CTA and will maximise the NOVA leadership in ELT instrumentation and in the development of the Einstein Telescope. Our main science breaks down into a series of categories, which we highlight below.

Fast Radio Bursts (van Leuwen, Pastor-Marazuela). After zooming in on the signal of the distant bursts, the astronomers found a striking similarity to the radio flashes emitted by nearby, known neutron stars [4].

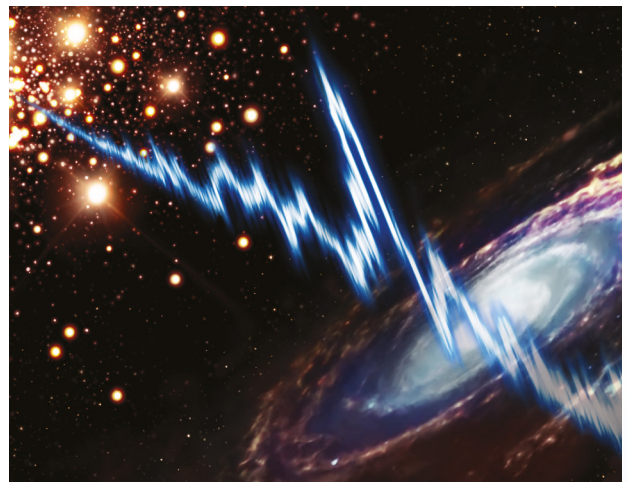

An artist's conception of a globular cluster, with timeseries data from a fast radio burst. From ref. [2].

How do relativistic jets and explosions shape our universe?

Amsterdam researchers (Russel, Degenaar) reported a proof-of-principle experiment that measured the jet speed of a neutron star through bright X-ray flares for the first time (finding it to be 40% of the speed of light) [5]. In Groningen, Méndez and his team used ten years of radio and X-ray observations to reveal the direct coupling between the accreting corona and the relativistic jet in the microquasar GRS 1915+105 [6]. Another Amsterdam team (Mösta, Curtis, Bosch, Shankar) significantly improved the computational modelling of jet-driven supernova explosions and neutron-star mergers. They presented the first 3D general-relativistic magnetohydrodynamic simulation of a neutron star merger remnant with detailed microphysics and M1 neutrino transport and studied the resulting nucleosynthesis and kilonova emission [7] and significantly advanced the state-of-the-art in supernova modelling on GPUs [8].

Pulsars

Pulsar clocks have opened a new window on gravitational waves. In June 2023 the first evidence for nanoHertz gravitational waves in pulsar timing array data was published [9]. This was done by analysing a decade of radio pulsar timing observations taken by five European telescopes, as part of the European Pulsar Timing Array collaboration, including the Dutch WSRT. This discovery has been in the making for 20 years, with several NOVA network contributions to it over the years. Amsterdam researchers have also measured the size of our nearest millisecond pulsar with NICER and constrained the dense matter equation of state and magnetic field geometry of the pulsar [10].

The X-ray and gamma ray sky

Gamma-ray burst 221009A was the brightest longduration gamma-ray burst ever observed — an event that we would expect to see only once every 10,000 years! — and NOVA researchers played key roles in characterizing it. Levan used JWST and HST to show that its extraordinary brightness was not matched by an unusually luminous supernova [11]. Comprehensive modeling from radio to GeV was presented by researchers from Radboud, Amsterdam, and ASTRON led by Laskar [12]. Notably, a transient, narrow emission feature in the prompt spectrum, best explained as a blue-shifted electron-positron annihilation line produced in the relativistic jet was reported by Radboud researchers (Ravasio, Jonker, Levan) [13]. This marks the first robust detection of a prompt spectral line in a GRB, suggesting that such features may generally be present but only observable in extraordinarily bright events like GRB 221009A.

NOVA astronomers have also played an important role in advancing understanding of GRB progenitor diversity. Levan et al. demonstrated that some “long” GRBs can originate from compact mergers rather than massive star collapse, with important implications for heavy element nucleosynthesis [14].

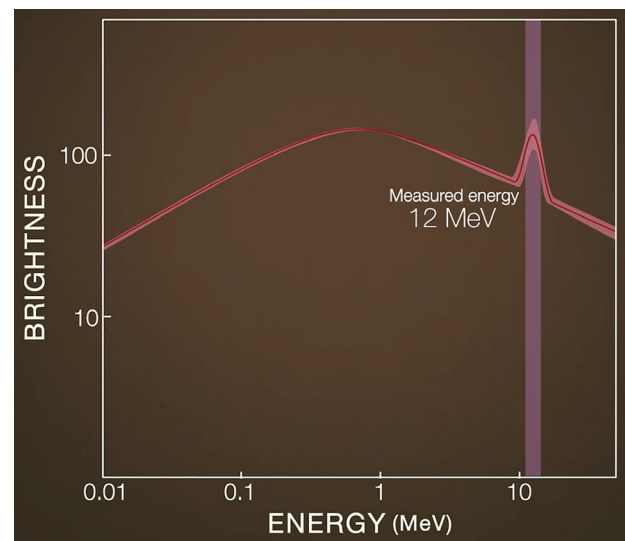

Spectra line seen in GRB 221009A. Adapted from [13].

Black hole horizons and accretion in Sgr A* and M87*

Following the striking first image of black hole in M87, the Event Horizon Telescope Collaboration (EHTC) has released the first direct image of Sgr A*, the black hole at the center of our Galaxy. A comparison of the shadow and variability of Sgr A* to simulations revealed how gas and magnetic fields behave near the horizon, advancing our understanding of accretion physics [15].

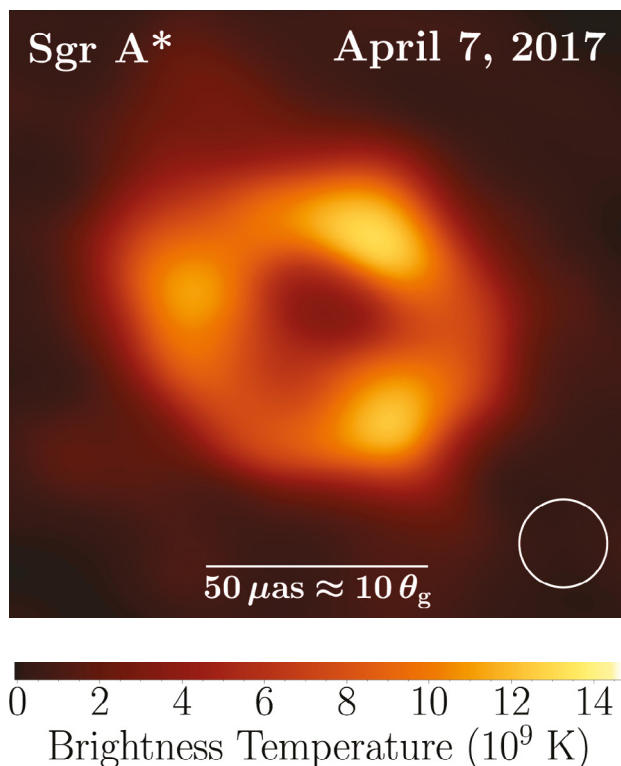

Representative EHT image of Sgr A* from observations on April 7, 2017. Adapted from [15].

Dutch researchers played a significant role in these results, with contributions from Radboud (Falcke, Janssen, Moscibrodzka, Davelaar, Fraga-Encinas, Issaoun, Jiménez-Rosales, La Bella, Olivares, Roelofs, van Rossum, Vos, Wondrak, Young, Yfantis), Amsterdam (Markoff, Porth, Musoke, Salas), Leiden (Impellizzeri, van Langevelde), and JIVE (Kettenis, Small, van Bemmell). A parallel, detailed analysis of Sgr A* polarimetric light curves from the Atacama

Large Millimeter/submillimeter Array carried out by [16] suggested a ‘hot spot’ orbiting Sgr A*, consistent with a magnetically dominated, dynamic accretion flow on horizon scales and strongly motivated polarimetric and dynamic studies of the source. In 2024, the EHTC presented the first resolved static linear and circular polarization images of Sgr A*, offering even tighter constraints on the magnetic field structure, geometry, and dynamics of the accretion region [17]. NOVA researchers played a particularly large role in the polarization analysis (Moscibrodzka, Yfantis) and in the EHT data calibration effort (Janssen).

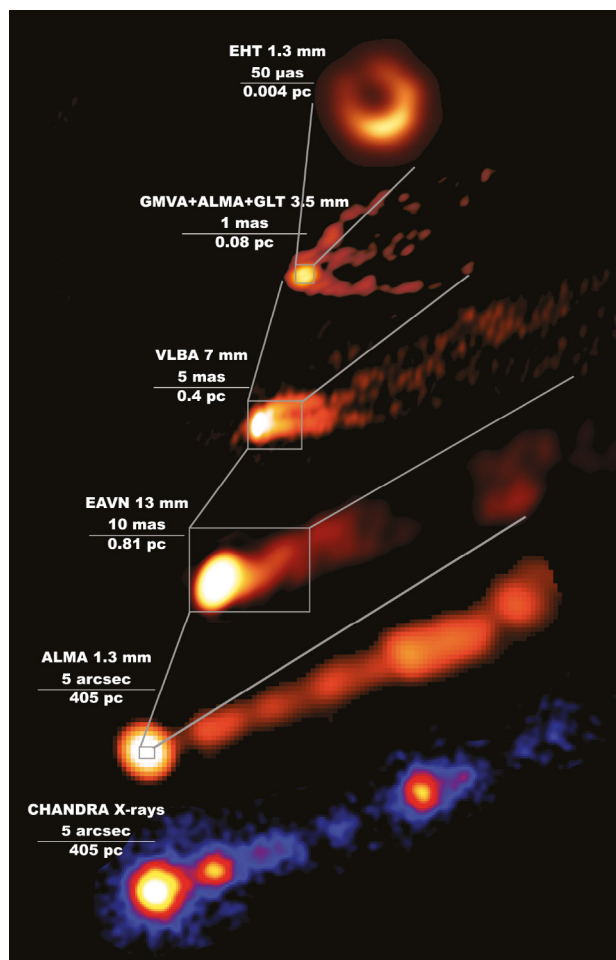

Composite of the M87 MWL images at various scales (with EHTC image from 2018 on the top) obtained from radio through X-rays during the 2018 EHT campaign [19].

The EHT also re-observed M87* in April 2018, producing independent horizon-scale images that revealed a ring with a diameter consistent with previous measurements in 2017, though with a shifted brightness asymmetry. This confirms the ring's persistence as emission produced in the vicinity of the gravitationally lensed photon ring around a black hole and tightens constraints on models of accreting plasma, turbulence, and jet alignment. NOVA astronomers have made extensive contributions to the theoretical interpretation of the 2018 M87 images [18] (Moscibrodzka, Salas, and Yfantis) and 2021 M87 EHT data calibration, analysis, and interpretation (lead by Janssen).

During the 2018 EHT campaign, simultaneous multiwavelength observations, co-lead by NOVA

astronomer Markoff, captured the first very high-energy γ -ray flare from M87 since 2010, with flux doubling in just 36 hours. X-ray flux was elevated compared to 2017, while radio and mm fluxes remained similar. These findings challenge simple one-zone emission models and suggest more complex particle-acceleration scenarios near the black hole or along the jet launched by the black hole [19], motivating future multiwavelength studies of M87*.

Looking ahead, the African Millimetre-wave radio Telescope (AMT) in Namibia—led by NOVA researchers (Falcke, Klein Wolt, Markoff, Janssen)—will become a key addition to the EHT, enabling full-color, high-resolution movies of black holes.

Gravitational Waves

With next-generation detectors such as the space-based LISA mission and the ground-based Einstein Telescope on the horizon, we are poised to explore new frequency windows and uncover the rich gravitational-wave backgrounds produced by compact binaries

and other cosmic sources. Radboud students Hofman and Staelens showed the collective gravitational wave signal of all double white dwarfs throughout the Universe dominates the astrophysical GW background in the mHz band, an important result for upcoming LISA

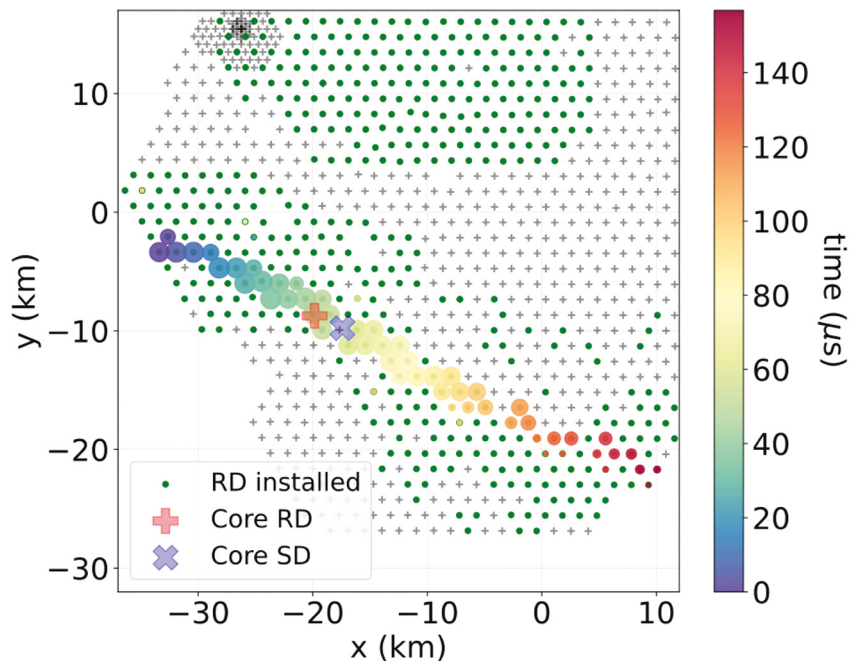

The radio footprint of a cosmic-ray air shower at the Pierre Auger Observatory, extending over 60 km.

analyses [20]. NOVA researchers at Leiden University and Radboud University have also developed the Gravitational Wave Universe Toolbox, a user-friendly GW simulator. This package will have an important impact on the GW population studies and on multi-messenger GW astronomy [e.g. 21].

NOVA scientists (Groot, Bloemen, Jonker) play a lead role in the BlackGEM telescope dedicated to measuring the optical emission from pairs of merging neutron stars and black holes. In the last three years, the BlackGEM array has transitioned from commissioning into full science operations and was officially inaugurated in 2024, marking the start of routine wide-field, time-domain surveys in the southern hemisphere. BlackGEM has regularly conducted rapid follow-up of LIGO–Virgo–KAGRA alerts, and has discovered and reported multiple nearby supernovae and other young transients to the Transient Name Server.

Acceleration of high energy cosmic particles

Even after a century of study, the origin of high energy cosmic rays still eludes us. Recent LHASSO results have suggested that Galactic cosmic rays likely come from distributed sources, upending the generally accepted paradigm that SNRs are the sole of Galactic cosmic rays. Work from Amsterdam researcher Kantzas (predating LHASSO’s discovery!) supports this new idea, demonstrating that most X-ray binaries in the Galaxy seem to be extreme particle accelerators, contributing to Galactic cosmic ray, gamma ray, and neutrino populations [22].

To probe the highest energy, extragalactic cosmic ray population, Hörandel led a team at Radboud to install antennas at the Auger Prime upgrade, significantly expanding the observatory’s power for identifying cosmic ray mass [23]. The figure above shows the radio footprint measured by the observatory extending over 60 km. Plans for the future Global Cosmic Ray Observatory are now underway. We also foresee that LOFAR2.0 and the upcoming SKA will revolutionize our view of air shower development (Mulrey, Hörandel), giving us unprecedented information about high-energy cosmic-ray composition. NOVA astronomers (Markoff, Vink, Vecchi) are also heavily involved in the CTA which will shed further light on the nature of cosmic accelerators, from Galactic supernova remnants to extragalactic GRBs.

Other NW3 developments

On the theoretical front, Wondrak, Falcke, and van Suijlekom (2023) proposed a novel black hole evaporation mechanism by drawing an analogy between spacetime curvature and an electric field in the Schwinger effect. This has implications for the nature of event horizons, constrains primordial black hole remnants as dark matter, and alters the matter–radiation energy density ratio in cosmology [24].

References:

- [1] de Ruiter, I. et al., 2025, *Nature Astronomy* 9, 672
- [2] Kirsten, F. et al., 2022, *Nature* 602, 585
- [3] Snelders, M.P. et al., 2023, *Nature Astronomy* 7, 1486
- [4] van Leeuwen, J. et al., 2023, *A&A* 672, A117
- [5] Russell, T.D. et al., 2024, *Nature* 627, 763
- [6] Méndez, M. et al., 2022, *Nature Astronomy* 6, 577
- [7] Curtis, S. et al., 2024, *ApJL* 961, L26
- [8] Shankar, S. et al., 2023, *Classical and Quantum Gravity* 40, 205009
- [9] EPTA Collaboration, Antoniadis J. et al., 2023, *A&A* 678, A48
- [10] Choudhury, D. et al., 2024, *ApJL* 971, L20
- [11] Levan, A.J. et al., 2023, *ApJL* 946, L28
- [12] Laskar, T. et al., 2023, *ApJL* 946, L23
- [13] Ravasio, M.E. et al., 2024, *Science* 385, adj3638
- [14] JWST collaboration, 2024, *Nature* 626, 737
- [15] Event Horizon Telescope collaboration, 2022, *ApJL* 930, L12
- [16] Wielgus, M. et al., 2022, *A&A* 665, L6
- [17] Event Horizon Telescope collaboration, 2024, *ApJL* 964, L25, L26
- [18] Event Horizon Telescope collaboration, 2025, *A&A* 693, A265
- [19] Event Horizon Telescope, Fermi Large Area Telescope, H.E.S.S., MAGIC, VERITAS, EAVN collaboration, 2024, *A&A* 692, A140
- [20] Staelens, S. & Nelemans, G., 2024, *A&A* 683, A139
- [21] Yi, S.-X. et al., 2022, *A&A* 663, A155
- [22] Kantzas, D. et al., 2022, *MNRAS* 510, 5187
- [23] Pierre Auger Observatory collaboration, 2023, *PoS ICRC2023*
- [24] Wondrak, M.F., van Suijlekom, W.D. & Falcke, H., 2023, *Phys. Rev. Lett.* 130, 221502



Francesca Rizzo

Can you tell us about your most recent discovery or a recent development you are excited about?

I am very excited about an ALMA Large Program, called CONDOR that I am leading. ALMA is one of the most powerful telescopes in the world for studying the cold gas from which new stars form. The CONDOR program uses 230 hours of observing time, a very large investment, to study a sample of “normal” galaxies when the universe was only a few billion years old, a period when galaxies were forming stars much more actively than today. What makes this project special is that these types of normal galaxies have rarely been observed in such detail before. Until now, ALMA has mostly focused on very unusual or extreme galaxies. With our new observations, which have almost been completed, we can finally begin exploring what typical galaxies looked like during this crucial period in cosmic history. Another exciting aspect is that we can combine the ALMA data with many other observations, including images from the James Webb Space Telescope. Together, these data will allow us to build the most complete picture so far of the stars, gas, dust, and even dark matter in these young galaxies. This will help us understand how galaxies formed and evolved.

How do you experience being an astronomer in the Netherlands and being part of NOVA?

Being an astronomer in the Netherlands means being part of a relatively small but highly collaborative community. This scale creates space for genuine interaction, open exchange of ideas, and active involvement in shaping the direction of the field. NOVA plays a central role in this environment: it brings the community together, creates opportunities for networking across institutes, and supports collaborations that would be difficult to establish otherwise. For me, this sense of connection and shared purpose is one of the great strengths of working in Dutch astronomy.

What do you hope to achieve in your professional work over the next year, and what role could NOVA play?

In the coming year, I hope to advance several key research projects, including the analysis of new large datasets and the development of new strategies and methods for interpreting them. NOVA can play an important role by continuing to support access to world-leading instrumentation and facilities that are essential for my work, from the ELT instruments (METIS, MICADO, MOSAIC) to ALMA, WEAVE, JWST/MIRI, and Euclid. NOVA coordination and leadership in these areas ensure that Dutch astronomers can fully exploit these facilities and remain competitive internationally.

If you could share one message about astronomy with the general public, what would it be?

Astronomy reminds us that the universe is vast, full of mysteries, and far bigger than the divisions we create on Earth. When we look out into space, national borders feel small and temporary compared to the cosmic scales we study. Exploring the unknown encourages curiosity, humility, and a sense of shared humanity; it shows us that focusing only on ourselves or on the boundaries between nations makes little sense in a cosmos that is so rich and interconnected. Ultimately, astronomy teaches us both how small we are and how extraordinary it is that we can understand anything at all.

MIRI: From design to discovery

Ewine van Dishoeck,
on behalf of the NL–MIRI team

Christmas 2021 was a day to remember: JWST was finally launched! Data from its four instruments have been flowing to the astronomical community since summer 2022. MIRI, the Mid InfraRed Instrument, is one of its four instruments built in a 50%-50% partnership between the US and Europe, with significant participation from NOVA. MIRI consists of a camera and a spectrometer covering the wavelength range from 5 to 28 microns, longer than any of the other instruments on

Webb. Europe was responsible for the optical system of the instrument, while the US supplied the detectors and cryogenic cooling system. NOVA developed and built the heart of the medium-resolution spectrometer. After a 25 year journey, astronomers are now enjoying the tremendous unique power of MIRI data to answer fundamental questions about the nature of the most distant galaxies, the formation of stars and planets, and the composition of exoplanetary atmospheres.

How MIRI came to be

The original plans for the Next Generation Space Telescope in 1996 called for a near-infrared imager and spectrometer at 1–5 μm , but a mid-infrared instrument ($>5 \mu\text{m}$) was only considered optional. At that time, Europe was fully immersed in data from ESA's Infrared Space Observatory (1995–1998, 2.5–240 μm) which demonstrated the rich science that can be done with space-based imaging and spectroscopy at those wavelengths. A small group of US and European scientists came together to jointly push the scientific case for MIRI, in particular its importance for characterizing high-redshift galaxies (the hydrogen H α line shifts to $>5 \mu\text{m}$ at $z > 6.7$) and for studying the cold and dusty environments of newly formed stars and planets. Its potential for exoplanet studies was realized only later when that field started to blossom >2003 .

The scientific and technical case convinced NASA and ESA to include a mid-infrared instrument, but initial concepts were just for an imager with a low-resolution

grism. The Dutch-led Short Wavelength Spectrometer (SWS) on ISO on the other hand showed the need for higher spectral resolution to resolve solid-state features, ices and gas-phase lines. Stimulated by an ESA-led Phase A study, a proper medium-resolution spectrometer (MRS, 5–28 μm , R \sim 3000) was designed that fitted within NASA's prescribed mass and cooling budget. Moreover, given Webb's unprecedented sub-arcsec spatial resolution, the team successfully argued for an Integral Field Unit that could obtain spectra at more than 100 positions simultaneously rather than a long-slit spectrometer that was still common at the time. Late 2001 MIRI obtained the green light to be built, with both sides of the ocean quickly agreeing on an equal partnership. Now the MIRI–MRS is the second most requested instrument mode on JWST! It demonstrates the importance of having a long-term scientific vision and not settling for less, as long as the instrument remains feasible within technical and budget constraints.

Building MIRI

In contrast with other JWST instruments, the MIRI European Consortium (EC) had to find national

resources to build its part rather than being financed by NASA or ESA. The EC consisted of 30 institutes

in 10 countries, with the UK taking the lead with Dr. Gillian Wright as PI. Given its expertise and track record with ISO-SWS and VLT-VISIR, it was natural for the Netherlands to focus its hardware efforts on the spectrometer, specifically the main optics of the MRS. Thanks to an early decision by the NOVA Board in 2002 to support MIRI, it was possible for the Netherlands to become a MIRI partner and then secure its main funding through a NWO-Groot grant. The NOVA Optical-Infrared group subsequently designed, built and tested the Dutch hardware, with ASTRON and TNO as subcontractors and SRON as contributor. Gabby Aitink-Kroes describes how the engineers closely collaborated to arrive at the very compact and seemingly simple layout of the complex MRS. It earned her the 2014 European Engineer Power Woman award. Nearly 50 companies contributed to the MRS. The Dutch-built hardware was delivered to the UK in 2008 to be integrated with the rest of MIRI. The complete MIRI instrument was delivered to NASA in 2012 as the first of the JWST instruments, ten years before launch. Since then, the NOVA team has mainly focused on its calibration and commissioning, including the development of high-level algorithms and scripts for the reduction and analysis of the MIRI-IFU data.

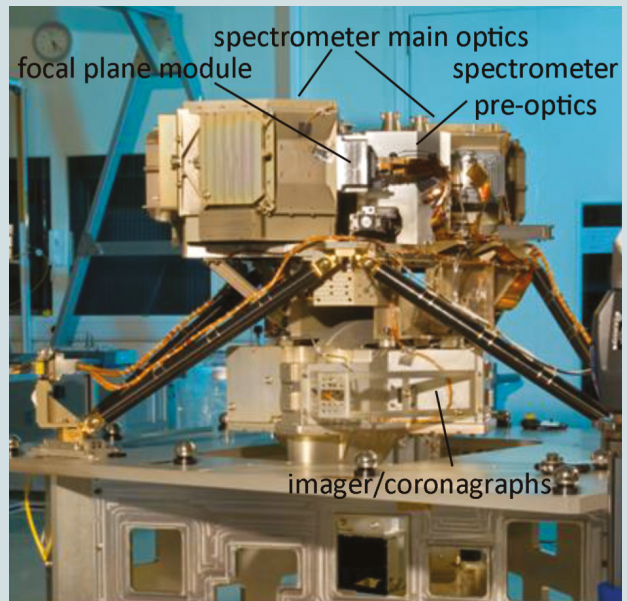

Complete MIRI instrument after integration in the UK, with the MRS on top (credit: STFC/RALSpace).



Designing the MIRI-MRS: Gabby Aitink Kroes (former NOVA Optical-Infrared engineer)

In 2000, NOVA brought the MIRI project to Dwingeloo; it was still in the feasibility phase, and a new fully reflective spectrometer design required investigation. I was fortunate to have the time and opportunity to work on the opto-mechanical design for this new layout, which was presented to ESA and NASA. With a small international team, we began developing MIRI, bringing together science and engineering from the start. I remember many face-to-face consortium meetings where scientists shared the potential of MIRI, and engineers contributed new ideas and possibilities. Over time

I saw an opportunity to improve the design, making our work easier while reducing risks for the entire instrument. Supported by senior team members, nationally and internationally, I took on the challenge of re-packaging the instrument. The new lay-out was successfully presented and adopted. All of this leading to the current success of MIRI on the incredible JWST. MIRI was a turning point for me, pushing me into a more leadership-focused role in instrument development. Today, good engineering continues to be my main motivation in such projects.

GTO programs

As a reward for its 20+ year investments, the MIRI EC received 450 hours of guaranteed observing time. The EC decided to put this time in three joint large GTO programs of each >100 hours – distant galaxies, exoplanets and protoplanetary disks – , one medium program on protostars, and a few smaller programs.

Dutch astronomers have a strong or leading role in each of these programs, being among the first to harvest MIRI science. GTO preparation started in 2010 and Łukasz Tychoniec (box) describes his experiences in planning one of those programs as a young student.



Planning MIRI GTO: Łukasz Tychoniec (Leiden)

I joined the MIRI EC in 2017 as a starting PhD student at Leiden. The planning of the MIRI GTO was then entering a decisive stage. The first version of the proposal tool for JWST was launched. With my expertise in protostellar sources, I was tasked to carefully select sources and observing strategies to make sure they fit within the allocated time. Discussing the strategy and MIRI specifications with the experts who developed the instrument over the course of decades was an invaluable experience that shaped my career. The key moment for me was witnessing the first datasets delivered,

where I could finally see, after years of waiting, that the tasks I was entrusted with were executed successfully resulting in beautiful spectral images. In the process, I learned a lot about user support and teamwork, which are essential for my daily job as a NOVA MIRI support scientist and ALMA Regional Center postdoc. Being one of the first scientists to work with JWST/MIRI data on forming stars has placed me in a highly privileged position, allowing me to explore uncharted territories enabled by the MIRI instrument's sensitivity and spatial resolution.

MIRI science

Numerous MIRI science highlights are described in the NOVA network reports. The MIRI deep field (see figure above) has allowed detection of numerous high redshift $z > 7$ galaxies in H α demonstrating their importance as sources of reionization. Closer to home, MIRI-MRS allows the physics and chemistry of the youngest,

deeply embedded protostars and their outflows to be probed on solar-system scales: their spectra are extremely rich in atomic and molecular lines as well as simple and more complex ices. Disks around young stars turn out to have a very diverse chemistry in their inner planet-forming zones: some disks have a lot of

H₂O, others CO₂. A major surprise is the finding that disks around very low-mass stars (<20% of the Sun) are extremely rich in hydrocarbon molecules such as CH₄, C₂H₂, C₄H₂ and even C₆H₆ (benzene) (see box by Aditya Arabhavi). Exoplanet atmospheres are probed with unprecedented precision by all four JWST instruments and show not just H₂O, CO₂ and CH₄ but even SO₂ whose origin is still debated. Also silicates (“sand clouds”) are uniquely found with MIRI, revealing intriguing weather cycles and atmospheric dynamics on distant worlds.

After three years of JWST operations, there are >500 MIRI publications of which 15% are from the GTO team having <10% of MIRI time. Another measure of success is the scientific demand for MIRI, which is high at ~35% of awarded JWST time, second only to NIRSpec: a testimony to the instrument builders! Overall, close to 100 astronomers in the Netherlands are working with MIRI data, and astronomers worldwide cannot imagine a JWST without MIRI.



MIRI GTO deep imaging survey of part of the Hubble Ultra Deep Field (2.1'x1.8') revealing thousands of distant galaxies of which hundreds are extremely red dust obscured sources studied by P. Rinaldi, K. Caputi and the MIDIS team. The MIRI-MRS is able to obtain spectra of several of the highest redshift galaxies. Credit ESA/Webb, NASA & CSA. <https://esaweb.org/images/potm2507a/>.

Outreach is an integral part of the NOVA program: the interest of the general public in JWST is huge. The JWST first images release on July 12 (led by a former NOVA PhD student) triggered enormous media interest, from all major Dutch TV and radio stations as well as newspapers, podcasts and social media, reaching millions of people. Numerous outreach events and public talks were organized throughout the Netherlands, from planetaria to schools. JWST was highlighted

during the Leiden European City of Science 2022 festival, and an exhibition featuring JWST images and art was held in the Leiden University hospital, including a children's lego corner. A new exhibition, JWST Universe, ran through 2023 in the Old Observatory.

We are eternally grateful to NOVA for playing such a large role in making this possible and putting the Netherlands on the world stage.



The JWST 1:10 moveable scale model displayed in the Pieterskerk in Leiden during the EuroScience Open Forum event in July 2022, with Ewine van Dishoeck showcasing the model to minister Robbert Dijkgraaf.

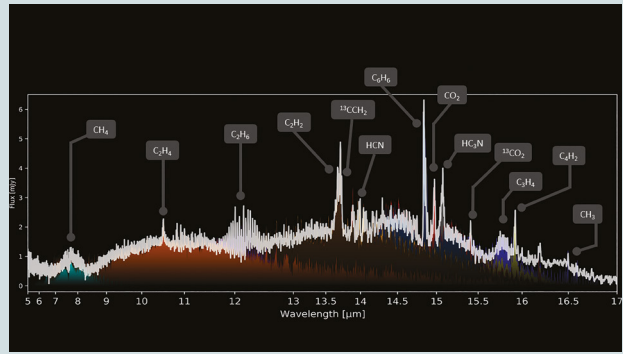

MIRI-MRS spectrum of the disk around a very low-mass star revealing a very hydrocarbon-rich chemistry with $C/O > 1$ in its planet-forming zone. Credit: A. Arabhavi, I.E.E. Kamp, E.F. van Dishoeck and the MINDS team.



Harvesting MIRI science: Aditya Arabhavi (Groningen)

Working with MIRI data has been a transformative experience. My time on the MINDS GTO team provided unparalleled access to cutting-edge observations of protoplanetary disks. It served as an intensive masterclass in astronomical instrumentation, data-reduction pipelines, molecular spectroscopy and frontier science. This environment allowed me to integrate modeling with observations, exploring instrument modes and the nuances of the mid-infrared sky to optimize exposure times, dither patterns, and target selection. Equally important, the GTO program taught me how to plan, organize, and disseminate large datasets while coordinating an international team, demonstrating that major scientific advances rely not only on technical expertise but also on effective project management.

The unprecedented fidelity of the MIRI data enabled significant breakthroughs in understanding planet-forming ingredients in protoplanetary disks. These observations not only revealed new molecules but also challenged and refined previous models, underscoring MIRI's unique ability to probe the origins of planetary systems. The professional network built through the GTO team continues to open doors, providing lasting collaborations and mentorship that will shape my future work. I am very grateful to the GTO team and NOVA for fostering such an environment with particular focus towards PhD students and postdocs.



Pierluigi Rinaldi

Can you tell us about your most recent discovery or a recent development you are excited about?

Since the launch of JWST, astronomers have uncovered “Little Red Dots” across the distant universe. At first, they appeared to be nothing more than compact red points when the universe was a tiny fraction of its current age; yet a closer inspection shows that they are far more complex than initially assumed. These objects likely hold crucial clues to how supermassive black holes grew in the early universe and how their growth shaped the evolution of their host galaxies.

How do you experience being an astronomer in the Netherlands and being part of NOVA?

Being an astronomer in the Netherlands was genuinely exciting. The NOVA network created a scientific environment that felt cohesive: institutes were well-connected, and people were consistently open to sharing ideas and expertise. That sense of unity made the research culture both productive and intellectually stimulating while I was in the Netherlands. It fostered an atmosphere where progress was driven not by competition but by collective effort, which is ultimately the foundation of good science.

What do you hope to achieve in your professional work over the next year, and what role could NOVA play?

I genuinely hope to return to the Netherlands and continue growing there. This job naturally takes astronomers all over the world, but working in the Netherlands felt uniquely rewarding. The environment was collaborative, supportive, and scientifically vibrant in a way that is hard to replicate. Returning would allow me to rebuild that atmosphere around my future work, and maintaining close collaborations with astronomers across NOVA would be an important part of achieving this.

If you could share one message about astronomy with the general public, what would it be?

I believe astronomy is not only about discovering the next exciting object or building the next instrument, although that is central to the field. What makes it truly meaningful to me is something deeper: the environments where people are eager to talk, collaborate, and share ideas. In those moments, astronomy becomes more than science; it becomes a way to experience life through collective curiosity. This feeling is not exclusive to astronomy, but the field has shown me how essential that sense of community is, and how important it is to cultivate it everywhere.

05

Instrumentation
Development



Sub-mm instrumentation

The NOVA sub-mm Instrumentation Group at the University of Groningen specializes in research and development of technology for submillimeter (THz) wavelengths. Its primary focus is supporting ESO's ALMA development program across all phases, such as the ALMA2030 roadmap and the Wideband Sensitivity

Upgrade. The group also tracks and contributes to developments at other submillimeter observatories, both ground-based and space-based, such as the Atacama Large Submillimeter Telescope (ATLAST), the Space Interferometer Initiative, and NASA's PROBE mission concept (FIRSST).

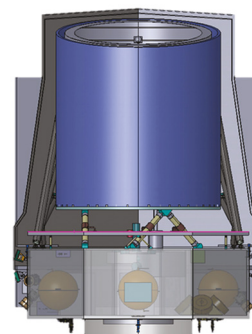
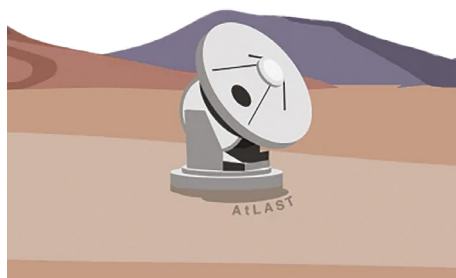

Illustrations of ALMA, ATLAST, and FIRSST initiatives (from left to right).

Sub-mm R&D

In the 2022–2024 period, the group mainly focused on the development of a 600–720 GHz ultra-wide-IF-band sideband-separating (2SB) receiver to be proposed as an upgrade for the existing double-sideband (DSB) ALMA Band 9 receivers. In addition to mitigating line confusion, for an atmosphere-limited band like Band 9, sideband-separation offers a significant benefit for spectroscopic observations, as it effectively halves the atmospheric contribution to the system noise, and therefore greatly reduces the required integration time to obtain the same signal-to-noise ratio.

Additionally, two ESO co-funded studies were active: the first one, titled ALMA Band 9 Sideband Separating Upgrade, had its kick-off meeting in March 2019, and

was successfully finished in February 2023. Towards a Producible ALMA2030-Ready Band 9 CCA, kicked off in October 2023 and continues to this day. The polarimetric performance is mainly limited by the polarization purity of the receiver and its beam squint (i.e., the misalignment of the two orthogonal polarizations on-sky). The causes of these, and various architectures to improve them fundamentally are being investigated. The final result of the study should be a fully functional prototype of a WSU-compliant ALMA Band 9 receiver. Both studies encompass the development of critical receiver components, from fundamental device physics and electromagnetic/optical simulations to mechanical design, manufacturing of prototypes, assembly and characterization in the lab.

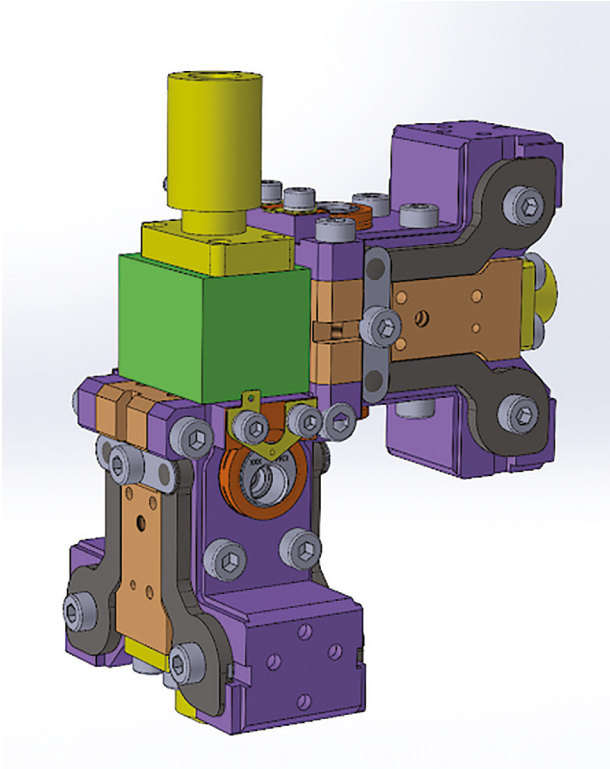

Preliminary design of two Band 9 sideband-separating mixers around an Orthomode Transducer (OMT, green block), a waveguide structure that separates the polarizations instead of a grid. The beam squint is the major detractor of the polarimetric performance and this is one of the possible solutions to reduce the beam squint essentially to zero.

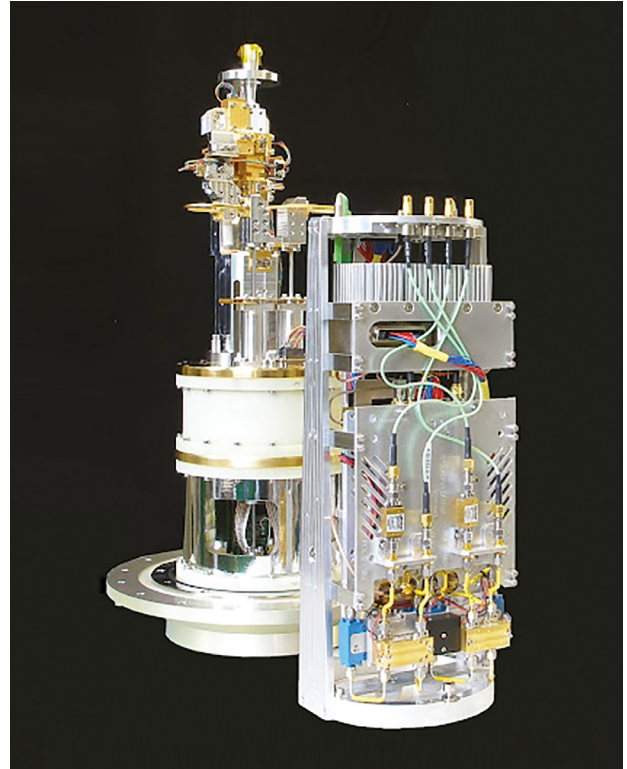

Left the Cold Cartridge Assembly and right the Warm Cartridge Assembly of the ALMA Band 2 receiver.

ALMA Band 2

Continuing the excellent track record of NOVA's submillimeter instrumentation group at the Kapteyn Institute in Groningen, which in the past have built the Band 9 and Band 5 receivers for the ALMA array, the group has over the past years been engaged in the development and production of the Band 2 receivers. As with the previous bands, these are built as a limited series production, with a total of 73 receivers to be delivered. NOVA leads the consortium producing the Band 2 receivers, which includes partners GARD in Sweden and INAF Bologna in Italy.

The Band 2 receivers use new technologies in microwave amplification and sensing to deliver very low-noise performance over a wide wavelength range from 67 to 116 GHz, essentially covering both Band

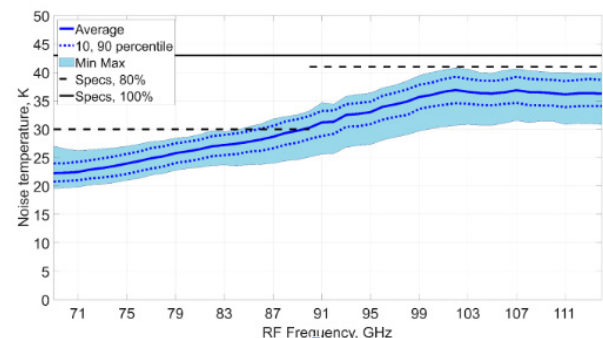

This graph demonstrates the excellent noise performance of the Band 2 receivers over a wide wavelength range. The data is based on the first 61 receivers produced, with the noise figure smoothed over 4GHz bins. Indicated is the average (solid blue) 10th and 90th percentiles (dotted blue line) and the minimum and maximum (light blue area). Horizontal lines are the requirements, over 100% of the range (top) and over 80% of the range (two lower lines).

2 and Band 3. They are the first of a new generation of receivers that will be installed as part of ALMA’s Wideband Sensitivity Upgrade.

During the period 2022–2024 the project has gone smoothly and excellent progress has been made. The

Critical Design Review was passed in November 2022 and the Manufacturing Readiness Review in September 2023. After that review, the full scale production phase was started, with 19 receivers delivered at the end of 2024 at a rate of around 3,5 receiver deliveries per month.

EHT

The Event Horizon Telescope (EHT) is a very long baseline interferometer, currently consisting of 12 mm–wave telescopes in Chile, Hawaii, Mexico, Spain, France, Arizona, Greenland, Korea, and the South Pole. The data measured by each individual telescope is linked together digitally to connect all antennas into a single virtual telescope that has the size of the Earth. The EHT has the highest resolving power in astronomy and is the only instrument capable of imaging black holes. NOVA scientists play a leading role in the steering and scientific output of the EHT and are currently working on building a Dutch–led telescope in Namibia – the Africa Millimetre Telescope – to join

the EHT. Currently, there are 453 members in the EHT collaboration, 29 of which are in the Netherlands.

The primary science goal of the EHT is to image black holes. For the low–luminosity active galactic nuclei (supermassive black holes in the center of galaxies that are accreting matter at a relatively low rate) M87* and the centre of our own galaxy Sagittarius A*, the EHT has resolved the millimetre–wave emission in the direct vicinity of the black holes. This emission is produced by synchrotron radiation and produces a characteristic ring–like structure with a dark spot in the center. This black hole shadow is a telltale sign for the presence

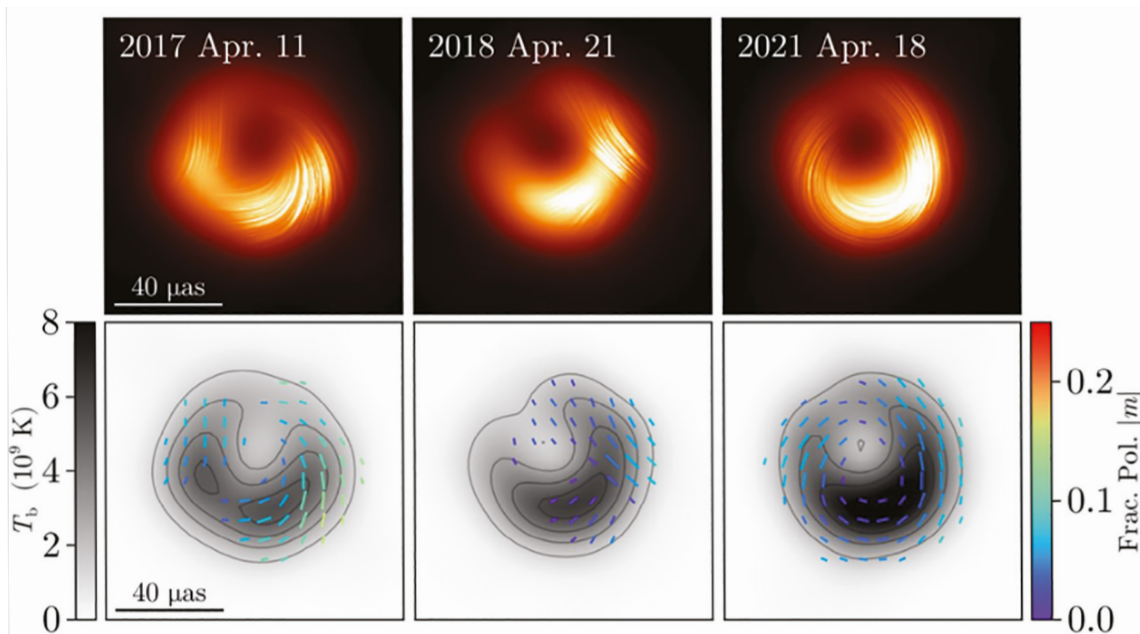

EHT linear polarization images of M87* over the years. The top panel shows “wind plots”, where the linear polarization field lines are overlaid on the total intensity images. The bottom row shows the total intensity brightness temperature as contours and with a gray scale, overlaid with colored linear polarization ticks. Taken from [1].

of an event horizon and allows for testing of General Relativity. Additionally, NOVA researchers can study the launching regions of extragalactic radio jets produced by a large sample of supermassive black holes. Combined with the observations at horizon-scales, this allows for the study of jet physics, accretion onto compact supermassive objects, and plasma physics in extreme astrophysical conditions.

Recent EHT results since 2022, with a strong NOVA contribution, include the first image of Sgr A* in full polarization, the detection of circular polarization on horizon scales in M87*, persistent detections of the black hole shadow in M87* in 2017–2021 with a significant variation in the polarization properties of the synchrotron emission, and the first VLBI detections at the to-date highest observing frequency of 345 GHz. In the near future, the goal is to upgrade the EHT with multi-frequency receivers across the array, spearheaded by the AMT frontend work of NOVA.

AMT

The Africa Millimetre Telescope (AMT) is an international collaboration led by Radboud University in partnership with the University of Namibia, Oxford University, the University of Amsterdam, and other institutions such as the University of Groningen, University of Turku and ASTRON. A 13 to 15m diameter radio telescope will be installed in Namibia to link to the Event Horizon Telescope (EHT) network which has produced the historic first-ever picture of a black hole and support the "colour movies" initiative under the BlackHolistic (European Research Council) grant, besides functioning also as a standalone Namibian telescope. NOVA supported the telescope

site selection decision assessment focusing on two candidate sites: The hard-to-reach Gamsberg (2.350m altitude) and a nearby, more accessible, site near H.E.S.S., at 1.950m altitude. In 2024 the AMT Delta-PDR was concluded. It was decided to first install the telescope at Göllschau near H.E.S.S. and to move the telescope to Gamsberg when the access road and funds have been resolved. Also it was decided to abandon the SEST antenna refurbishment in favour of procurement of a new antenna. In 2024, at the start of Phase 6, NOVA decided to contribute to the AMT Front End development.



Gamsberg as seen from road D1483. <https://commons.wikimedia.org/wiki/User:Theseus>

CTAO

The Cherenkov Telescope Array Observatory (CTAO) will be the next global facility for gamma-ray astronomy, detecting photons from ~20 GeV to ~300 TeV with 2–9 arcmin angular resolution and a 4–9° field of view. It is being built at two sites: CTAO–North on La Palma (14 telescopes) and CTAO–South near Paranal, Chile (50 telescopes). Headquartered in Bologna, CTAO is a European–led effort with global partners. Its main goal is to study the origin and acceleration of cosmic rays in Galactic and extragalactic sources, with additional science cases including indirect dark matter searches, axion physics, and Lorentz invariance tests. Its wide field, precision, and sensitivity also make

it ideal for following up gravitational–wave and high–energy neutrino events.

Since 2007, NOVA has been a partner in CTAO, contributing to the cameras for the small–sized telescopes (SSTCAMs) at CTAO–South (35 planned), supported by an NWO–Groot grant and NOVA funding. The SSTCAM consortium includes institutes from Germany, the UK, the Netherlands (UvA, RUG, NOVA submm group), Australia, and Japan. From 2022–2024, NOVA helped update SSTCAM designs and set up its submm lab for series production of the focal plane assembly, scheduled for 2026–2028.

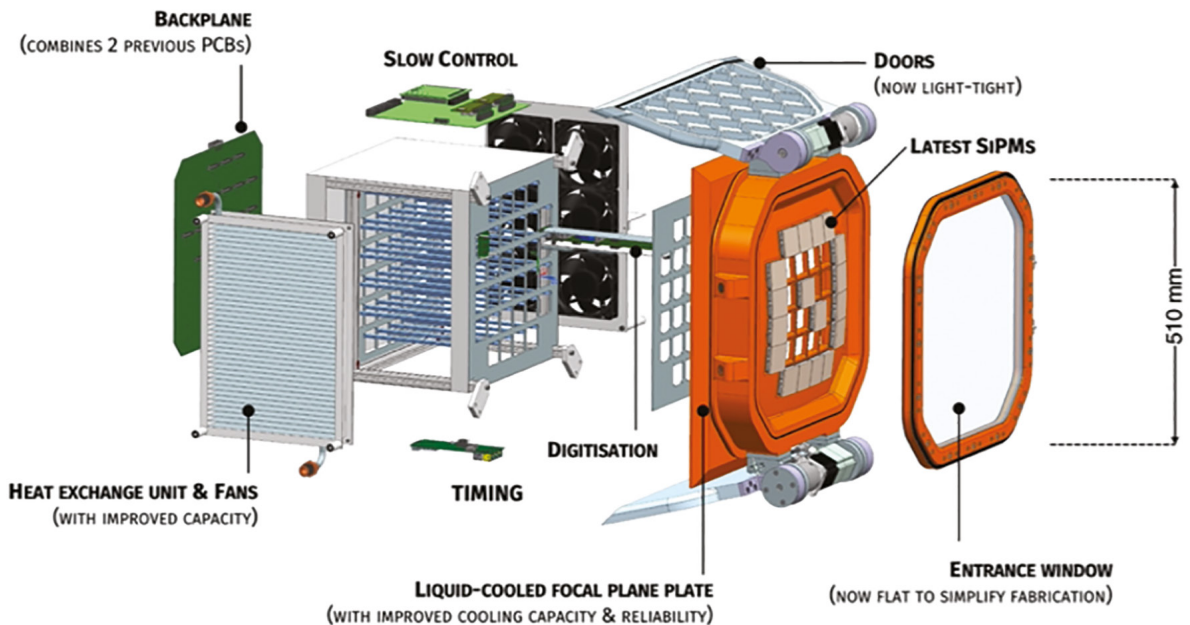

Top panel: the SSTCAM design. NOVA will be responsible for the production of the focal plane assembly, requiring careful mounting of the SiPM detectors and electronics, and mechanical parts. Bottom panel: NOVA submm group personnel testing the assembly procedures for the focal plane assembly.



Sebastiaan Haffert

Can you tell us about your most recent discovery or a recent development you are excited about?

One of the exciting things that happened recently is the discovery of the exoplanet WISPIT 2b. It's a young baby planet that is still growing while carving a gap in the circumstellar disk. This is the first planet we have found within such a gap, offering a unique opportunity to study planet formation in action.

How do you experience being an astronomer in the Netherlands and being part of NOVA?

The Netherlands is an excellent place for astronomy, in particular in my specific research area, which focuses on the development of the next generation of astronomical instruments and telescopes. The collaboration between the four institutes through NOVA allows us to have a much greater impact than we could achieve individually.

What do you hope to achieve in your professional work over the next year, and what role could NOVA play?

We are currently working towards the design of a new instrument for the Extremely Large Telescope. I would like to make significant progress on the design and position the Dutch astronomical community as a major consortium partner. This will be done within the NOVA collaboration.

If you could share one message about astronomy with the general public, what would it be?

Astronomy is fun and interesting. It allows us to explore and be creative within the natural sciences while trying to understand our origins and future.

Optical–Infrared Instrumentation

The NOVA Optical–Infrared (Op–IR) Instrumentation Group in Dwingeloo has a longstanding heritage of designing, developing and manufacturing (sub–) systems for observations in the optical and infrared wavelength range. The group specializes in cryogenic instruments, most notably spectrographs, and

systems engineering of complex subsystems that require high–precision manufacturing. The instrument development is focused on the ESO–program, but also supports the Isaac Newton Group of telescopes and other observatories.

WEAVE

WEAVE is a multi–object spectrograph capable of measuring spectra of up to 1000 sources in a single observation. One of its most prominent science cases is to determine radial velocities for millions of stars in order to complement existing Gaia data and complete position and velocity information for all objects, enabling a complete reconstruction of the Milky Way Galaxy. WEAVE had its technical first light on June 16, 2022, leading to the publication of the first–light science paper. Multi–Object Spectrograph (MOS)

commissioning revealed several issues, including strong internal astigmatism. The NOVA–led Spectrograph Tiger team, formed in mid–2024, successfully restored four of the five resolution modes to nearly nominal performance by realigning key optical elements. Concurrently, the WEAVE positioner consistently achieved 0.3" RMS astrometric accuracy, meeting essential requirements, and autoguider refinements yielded stable 0.8" images. WEAVE is now ready to start its five–year community survey.

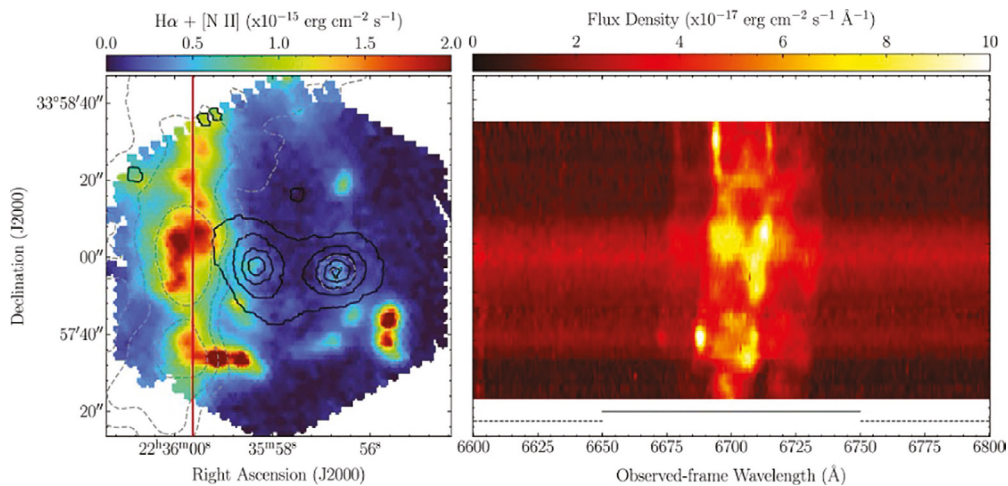

Weave. WEAVE's first light observation of Stephan's Quintet [2]. Left: $H\alpha + [NII]$ emission from the shocked and star-forming gas in the group. Right: the 2D spectrum of the shocked region (red line in the left panel) around $H\alpha + [NII]$, showing the complexity of the gas motions and ionization.

4MOST

4MOST is a wide-field high-multiplex survey facility for the VISTA telescope of ESO. Two low-resolution and one high-resolution spectrograph, simultaneously measure spectra of nearly 2500 stars in a 2.5 degree diameter field of view. The goal is to complete a full sky survey in seven years time, measuring over 20 million spectra. 4MOST addresses many science cases simultaneously. One of them is providing the missing information on the third dimension in ESA's Gaia mission.

NOVA's hardware Work Package is to build the 4MOST Calibration System. This is used in three ways, for i) Wavelength calibration (absolute and relative), ii) for simultaneous calibration and monitoring of the spectrographs, and iii) for fiber flat fielding. The Calibration System will also measure variations in the light coming from the optical fibres. The NOVA concept meets the three uses in one system, providing several highly stable sharp spectral features, high power and mimicking the sky over the full field of the focal plane. It is a unique system, highly innovative yet based on well known optical principles in three main units. The power box contains the power supplies, a laser driven light source and vacuum equipment. The light box contains a thermally stabilized Fabry-Perot etalon

in a vacuum environment, a spectral line lamp and a series of filters with mechanisms. The light sabres illuminate the Telescope primary mirror with calibration light from the spider structure holding the secondary mirror. Various optical fibre systems couple all these units in the calibration system.

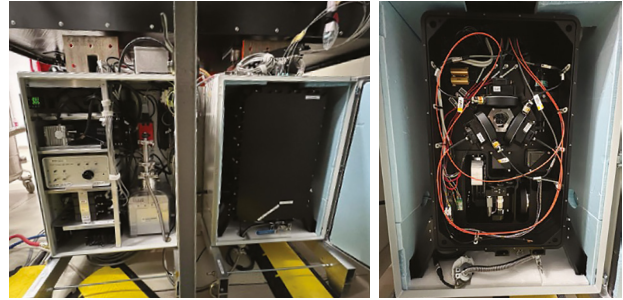

The 4MOST calibration system has been integrated at AIP in Potsdam since August 2022. The left image shows the powerbox on the left and the optical box on the right, while providing calibration light for the spectrographs during system level testing. The contents of the light box are shown in the second image.

HARPS3

HARPS3 is a cutting-edge spectrograph being installed on the Isaac Newton Telescope on La Palma, Spain. This telescope will be robotised in order to conduct the Terra Hunting Experiment, a 10-year-long radial velocity survey at unprecedented precision to search for Earth-like planets around Sun-like stars. NOVA has developed the Cassegrain and Calibration Unit. In the 2022-2024 time frame, the subsystem was completed and shipped to Cambridge (UK) for integration. First light is expected in late 2025.

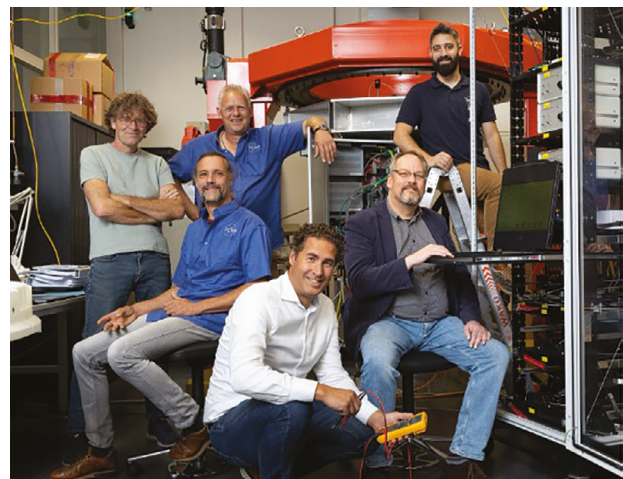

The proud NOVA HARPS3 team upon delivery of the CAS+CAL subsystem.

BlackGEM

The BlackGEM telescope array consists of three wide-field telescopes that are located at the ESO La Silla Observatory in Chile. NOVA, Radboud University and the KU Leuven are the leading partners in the consortium, which further consists of 15 other institutes around the world. The BlackGEM project is led by its Project Office located at Radboud University. BlackGEM is in operation every clear night, and all data is processed immediately in a dedicated cloud environment such that final results are available within 15 minutes of the initial data coming in. This enables a fast turn around in scientific follow-up, as required by the short time scales of phenomena such as kilonovae. The wide-field telescopes were designed and built by NOVA, and include innovative elements such as the carbon-fibre frame, the wide-field atmospheric dispersion corrector and a fast piezo-mounted secondary mirror corrector, which may allow future low-order wide-field adaptive optics tip-tilt corrections.

The scientific aim of the BlackGEM array is to uncover optical counterparts to gravitational wave events as well as to understand the transient and explosive Universe in a more general sense. To this purpose the robotic telescope array reacts fully autonomously to triggers from the LIGO–Virgo–KAGRA (LVK) laser interferometer systems that detect gravitational wave mergers, and at the same time scans the nearby Universe for the earliest signs of new supernovae, tidal disruption events, novae, and other explosive phenomena. In a special program BlackGEM is also charting the Milky Way stellar population for ultracompact binaries that are to be seen with the LISA Space Interferometry mission, the next ‘L’-class, gravitational wave mission to be launched by the European Space Agency.

In April 2023, the BlackGEM started its scientific operations phase, which will last five years until April 2028. The array was inaugurated in January 2024 by then-minister of Education, Culture and Science of The Netherlands, prof. Robbert Dijkgraaf.



Minister Dijkgraaf inaugurating the BlackGEM Array at the ESO La Silla Observatory on January 9, 2024.

NUX and proto-NUX

The Nova Ultraviolet eXplorer (NUX) is a concept for a ground-based, wide-field near-ultraviolet (300–350 nm) observatory aimed at studying fast astrophysical transients. Key science targets include shock breakout and cooling emission from supernovae, electromagnetic counterparts to neutron star mergers, and the emission of tidal disruption events and superluminous supernovae. Developed in collaboration between the University of Amsterdam, Radboud University, and NOVA, NUX will employ multiple 35 cm telescopes retrofitted with UV-transparent and UV-reflective optics. The project successfully passed its preliminary design review in spring 2023. Following this milestone, additional funding was obtained from the University of Amsterdam and NOVA to construct a prototype instrument, proto-NUX. The purpose of proto-NUX is twofold: first, to address outstanding technical aspects of the design; and second, to provide empirical measurements of atmospheric transmission in the near-UV and to quantify the instrument's sensitivity under realistic conditions. Assembly is scheduled for autumn 2025, with deployment to La Silla, Chile, for on-sky testing in spring/summer 2026. These tests will provide essential input for the further development of the full NUX facility and help establish the near-UV performance achievable from the ground.



Hans Ellermeijer (UvA; left) & Rik ter Horst (NOVA; right) dismantling the mirror of proto-NUX so it can be recoated with a NUV reflective coating.



Proto-NUX assembled (without the replaced optics yet) at the UvA for testing.

ELT

One of the pillars of the NOVA instrumentation program is its contribution to the Extremely Large Telescope. The largest optical telescope in the world that is currently being realised on Cerro Armazones in Chile. NOVA has created a strategic roadmap, and obtained associated funding, to contribute to the first three generations of ELT-instrumentation. NOVA is

contributing to the development of subsystems of METIS, MICADO (both first-generation instruments), MOSAIC (second generation instrument) and PCS (third generation instrument). Moreover, NOVA is leading the METIS consortium, and its full system integration will take place in the Netherlands.

PCS R&D

ELT-PCS is the Planetary Camera and Spectrograph for the ELT, addressing its number-one science question: are we alone in the Universe? It will obtain direct images of a small sample of rocky planets in the habitable zone of stars where liquid water could be present and search for biomarkers that could indicate the presence of life. Within the ESO community, NOVA – and in particular the optical lab at Leiden University – already plays a key role in this endeavour, with the development of many novel components and techniques to achieve very high contrast. The Dutch PCS R&D technology development program started in the summer of 2024. NOVA has already made the first steps towards PCS, by creating a real time Neural Network interface for the MagAO-X instrument with the TensorRT library from NVIDIA. The Neural Network-based control system was deployed on-sky in November 2024. This was the first successful on-sky demonstration of a high-order AO system controlled at high speed (2 kHz) by a Neural Network. The development of this software interface paves the way

for further exploitation of Machine Learning techniques for the XAO module of ELT-PCS.

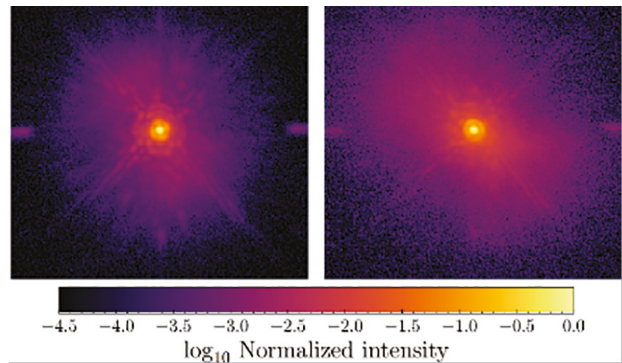

On-sky PSFs obtained with the Neural Network and unmodulated pyramid wavefront sensor (left) and the standard operation with the modulated pyramid wavefront sensor (right), showing an improvement in imaging quality. Adapted from [3].

MOSAIC

The Multi-Object Spectrograph for Astrophysics, Intergalactic medium studies and Cosmology (MOSAIC) is one of the instruments planned for the ESO Extremely Large Telescope (ELT). It is a versatile multi-object

spectrograph working in both the Visible and NIR domains, designed to cover the largest possible area (~40 arcmin²) on the focal plane provided by the ELT. The design is optimized for key capabilities such as

high survey efficiency, high sensitivity to faint targets, and covering an extended parameter space, in terms of available modes (MOS & mFU), bandwidth, spectral resolution, for the wavelength range from 450 nm (goal 390 nm) – 1800 nm.

As part of a large consortium including 24 partners, with LAM Marseille being the PI institute, NOVA leads the VISible spectrograph work package and manages the overall VISible Science Channel in close collaboration with other consortium partners. The VIS Science Channel is planned to have separate low – and high-resolution fibre link feeds, a dual-beam two-camera design to split the spectrum (in blue and

red arms) providing full simultaneous coverage from 390nm–950nm in low resolution and a few high-resolution bands in the same wavelength range.

Following green light from ESO in December 2021 and a reorganization of the consortium in 2021–22 to prepare for a preliminary design phase (Phase B), the Phase B1 Agreement was signed with ESO in March 2023. This marked the kick-off for the MOSAIC phase B1, leading towards the Specification and Architecture Review (SAR) in April 2025. Since 2024, NOVA has chaired the MOSAIC Board. Following SAR, Phase B2 will start, leading to the Preliminary Design Review (PDR).

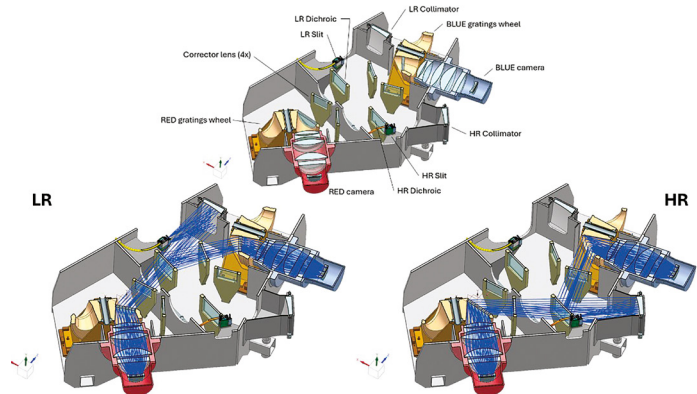
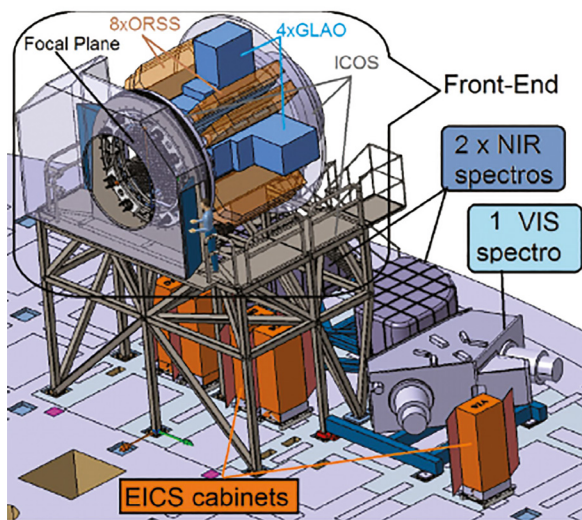

On the left: an overview of MOSAIC (~30m×15m) on the Nasmyth Platform of the ELT. Shown here are the Front End (and its subsystems), the Visible Spectrograph, the Near-Infrared Spectrographs, and Electronics and Instrumental Control System cabinets, and on the right; a cross-sectional view of the optical layout of the VIS Spectrograph.

MICADO

MICADO is designed to work at the diffraction limit of the ELT, and thus the highest spatial resolution filled aperture images ever achieved between 0.8–2.5micron observing wavelength, which is a factor 6 higher than the James Webb Space Telescope. This capability will allow uniquely detailed images and precision astrometry of compact, currently unresolved, targets with many different components crowded together, and thus it opens up a unique new parameter space on milli-arcsecond spatial scales. This will be a scientific

treasure trove, with broad impact across astronomy, from the Solar system, exoplanets, stars and black holes to galaxy formation, evolution and dynamics, both near and far.

MICADO passed ESO’s review of the final design in this period. NOVA Op-IR is providing the Pupil and Filter wheel mechanisms as well as the Atmospheric Dispersion Corrector (ADC). The scientific calibration plan and associated design of processing software and

platform have also been delivered by NOVA through the Kapteyn Institute. Moreover, NOVA provides the project scientist.

The NOVA Op-IR group was the first partner to cryogenically test any of the cold subsystems that go in the MICADO cryostat. This started in April 2024 with the pupil wheel mechanism in the cryostat at MPE and will be followed with the whole central wheel mechanism (pupil wheel plus two filter wheels) in 2025. The tests have been a success. The hardware functions according to specification in both warm and cold conditions. The filters that will be placed in these wheels are presently being coated, the first filters have been delivered and tested in Dwingeloo. The ADC will be assembled and tested later in 2025 and beginning of 2026. The prisms for the ADC have been manufactured to specification, and delivery is expected at the end of summer 2025.



The MICADO pupil wheel mechanism, placed into the test cryostat at MPE for testing in March 2024.

METIS

The mid-infrared ELT imager and spectrograph (METIS) is one of three first-generation science instruments for ESO's ELT. The project started in 2015, is being led by NOVA and is supported by 12 consortium partner institutes from Europe, US and Taiwan.

METIS passed its final design review (FDR) in Nov 2022 (with the exception of the data pipeline, which had its FDR in November 2023), and all critical actions were successfully completed within one year. Subsequently, the procurement of hardware started at essentially all partner institutes. Furthermore, all 15 ICAR cryogenic mechanisms have been successfully tested, and the cryogenic derotator unit has been assembled and completed cryogenic testing at ESO Garching. The N-band detector – the so-called GeoSnap, manufactured by Teledyne Imaging Systems – has been received and tested at the University of Michigan. The first of the new NGC-II detector controllers, designed and built by ESO, has been received and tested. Most major optics components for the NOVA-led common fore-optics (CFO) are near completion and the immersed grating from Canon has been completed. A very important step for the manufacturing of the immensely large and complex CFO was the acquisition of the new Grob milling machine by NOVA.

Apart from the work of the METIS Project Office, most of the activities in Leiden focused on the preparation of

a facility for the assembly, integration, and testing (AIT) of METIS. For that purpose, the Kamerlingh Onnes Lab has been completely refurbished and equipped with the necessary facilities, including a 10-ton overhead crane. Since the AIT phase (~2026–2028) will be very work – and labor-intensive, an AIT test team has been formed with members from most consortium partners, as well as an operations-team (see also section Long-Term archiving). While many technical and financial challenges remain, METIS is on a good track toward first light at the ELT in 2029/30.



The METIS cryostat in the assembly support frame (in Buchs, Switzerland), being prepared for thorough testing before shipping to the NOVA AIT facility in Leiden. © ETH Zurich.



Marielle Bekema

Can you tell us about your most recent discovery or a recent development you are excited about?

My recent work is, in a way, long-term work. We are close to finishing the Band 2 project for ALMA, and this marks my 21st year working as an engineer on the project — from Band 9 to Band 5 and now Band 2. I am responsible for the assembly of the receivers, including providing assembly input during the design phase, inspecting incoming components delivered by industry, writing manuals and reports, and carrying out the final assembly of the receivers.

How do you experience being an astronomer in the Netherlands and being part of NOVA?

I started as a technician, making cable harnesses for Band 9, and was soon asked to assemble receivers. In the years that followed, I learned a lot and took on more responsibilities. I completed a professional bachelor's degree when I was fifty. NOVA is a challenging environment for all of us, from technicians to professors. Learning never stops. For that reason, I do not look forward to retirement; I cannot imagine a better place to satisfy my curiosity. Working in a small team is super. Because we need overlap in different activities to build and test a receiver and ensure continuity, I feel strongly responsible for the entire project. I did my thesis with the NOVA optical group and joined other engineers in the BlackGEM project. It is great to share knowledge and collaborate with other groups.

What do you hope to achieve in your professional work over the next year, and what role could NOVA play?

In the next few years, I hope to build the next receiver series, Band 7, and assemble the focal planes for the CTA small-sized telescopes. Most importantly, I want to transfer my knowledge to the next generation of technicians and engineers. I have built up a great deal of experience, especially in Product and Quality Assurance. For the last SPIE conference, I made a poster on this subject, and I am currently preparing a presentation that can be used in lessons for technical personnel or schools.

If you could share one message about astronomy with the general public, what would it be?

It is very important to learn more about the universe and to understand its history and future, as this makes us more aware of how unique our habitat is.

Space, Software & Data Science

NOVA maintains a diverse instrumentation portfolio, spanning much wider than the primarily ground-based projects at its instrumentation groups. NOVA is also contributing to various space missions, in both hard — and software, other instruments and technology

developments. This diverse portfolio enables NOVA researchers to remain at the forefront of astronomical science, while the NOVA instrumentation program remains also strategically invested in future key technology development.

MIRI

Following launch late 2021, JWST and its instruments were deployed in the first half of 2022. NOVA designed, built and tested the MIRI spectrometer main optics, delivered in 2008, and contributed to providing and testing calibration data products, pipeline infrastructure and algorithm definition in the 2008–2021 period. In 2022, NOVA was part of the MIRI commissioning team at STScI in Baltimore, with the instrument performing near flawlessly after it cooled down by mid-April 2022.

After commissioning, NOVA efforts turned to further instrument characterization and calibration support in 2022–2024, with a focus on improving procedures for removing fringes from MIRI IFU data for extended sources. The goal of sub-percent level accuracy is now within reach, and MIRI spectra turn out to be very rich in lines and features. Also, the Dutch team provided user support for the annual GO proposal calls in 2022–2024 and helped students and staff in reducing and analyzing the first MIRI data. Several nation-wide community workshops were held in this period. As

a result, the NOVA community was able to quickly harvest the MIRI science, with several high-profile papers published quickly after receipt of data.



The NL MIRI team celebrating the successful commissioning of JWST and its first images and spectra in July 2022 in Dwingeloo, 14 years after delivering the spectrometer main optics hardware. Credit: R. Navarro.

Gaia

Gaia is the currently most impactful European space astronomy mission. It has revolutionized astronomy through the vast set of fundamental astronomical data that touches on every topic in astrophysics. Gaia produces a map of the 3D positions and motions of the

stars in our home galaxy, the Milky Way, and collects detailed data on the colours of the stars, which allows the estimation of their astrophysical parameters, such as their ages and chemical compositions.

During this triennial, the highlights for the Gaia mission were the publication of the third data release and the focused product release. These releases constitute a vast expansion of the astrophysical data on stars in the Milky Way. This includes 220 million low resolution prism spectra from which the earliest proto-galactic fragments and the early evolution of the Milky Way disk have been reconstructed. Another highlight is the spectacular discovery of the most massive black hole of stellar origin.

NOVA contributes to the data processing effort for the Gaia mission, particularly the processing of the colour information for the stars and the crucial task of validating the Gaia data products before they are published. In addition, the Executive of the Gaia Data Processing and Analysis Consortium is chaired by a NOVA staff member, and NOVA provides significant support to this activity.

Gaia data releases are made available worldwide without a proprietary period for the data processing consortium, which puts this project at the forefront of open science.

Euclid

ESA's Euclid satellite was successfully launched on 1 July 2023. After a long preparation, started by RuG-Target in 2009 and supported by NOVA from 2014 onwards, the Dutch formal contribution to the Euclid Consortium consists of designing, building, qualifying and operating data handling components for the processing by 9 distributed datacenters. Euclid's archive will contain dozens of Petabytes of image data of the satellite and even more data from ground-based observatories, which is co-led by a NL team. The core of Euclid's Archive System is based on AstroWISE concepts, developed by NOVA since 2001.

After an intense commissioning period the first Euclid images were published on 7 Nov 2023. The satellite data meet the required high spatial resolution and depth and on 14 Feb 2024 the sky survey started, which in total will take ~6 years.

From then on the NL partners, Leiden Observatory (involved in the near infrared pipeline), the Kapteyn Institute and the Computing Center of the RuG hosting the NL Science data Center were intensely working on

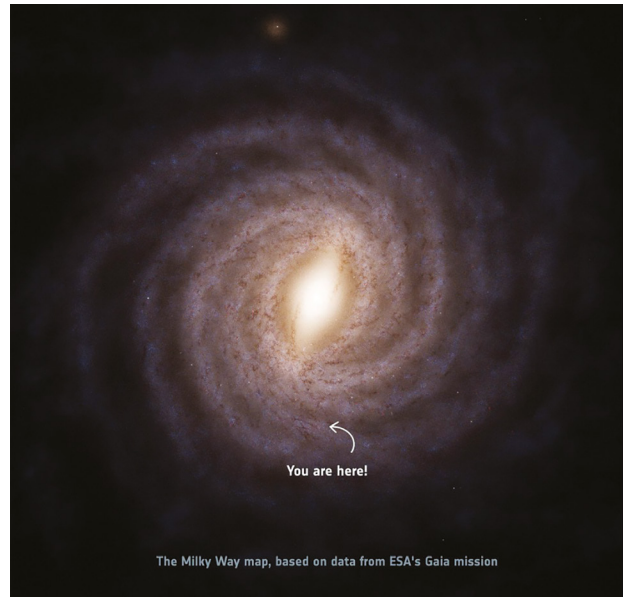

A model image of what our home galaxy, the Milky Way, might look like face-on: as viewed from above the disc of the galaxy, based on Gaia data. The location of the sun is indicated. Credit: ESA/Gaia/DPAC, Stefan Payne-Wardenaar, CC BY-SA 3.0 IGO.

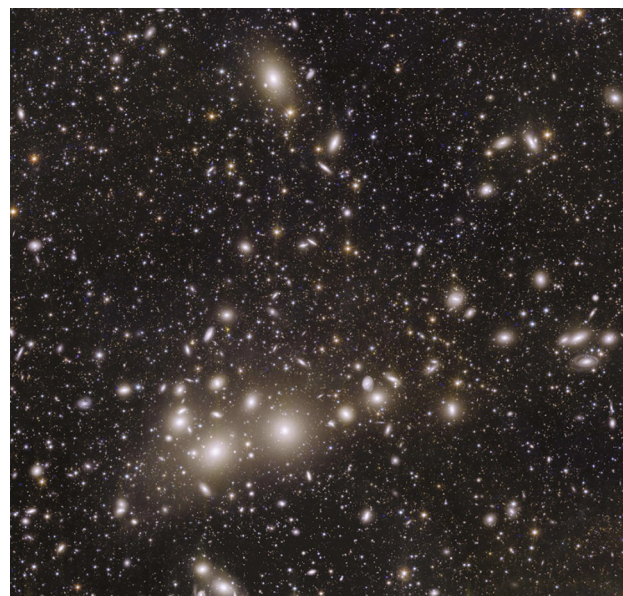

One of the very first images taken by the Euclid satellite. The image shows 1000 galaxies belonging to the Perseus Cluster, and more than 100 000 additional galaxies further away in the background.

the first internal data release Q1, expected early 2025, which would mark a major achievement in the Euclid mission. The NL community and the Euclid consortium,

with its ~3.000 members, can proceed to exploit the data coming from Euclid's surveys.

neXTsPec

neXTsPec is a project, completely performed by NOVA, to develop next-generation software for analysing and modelling multi-dimensional data which is provided by state-of-the-art current (e.g. NICER) and upcoming (eXTP, Athena) X-ray observatories. These missions probe the rapid X-ray variability which originates close to black holes and neutron stars in bright X-ray binary systems. Previously, the study of these variations was limited to either fitting only the X-ray spectrum, or modelling only the time variability at one or two energies, thus losing a lot of information that comes from the combination. The neXTsPec software (now

known as ndspec) can simultaneously account for the instrument calibration to model the variations as a function of both energy and time, providing powerful causal constraints on the structure of the inner regions. The figure below shows the data, model and residuals for a fit to NICER black hole X-ray data assuming distinct time lags from the main spectral components. By fitting both spectral and time-variability together, we can obtain much stronger constraints than possible before, on the underlying physics of the extreme regions close to black holes and neutron stars.

Long-term archiving and data mining

The NOVA Long Term Archive (NOVA-LTA) is hosted by OmegaCEN, the Kapteyn Astronomical Science Data Centre. It contains the archives of the MUSE spectrograph, MICADO simulated images, the OmegaCAM imager including the full KiDS 1347 Square degree survey and several other wide-field imagers. The archives facilitate scientific research projects and have ~500 registered users. These archives use the AstroWISE Information system and/or technology. This NOVA asset has been re-used in the Euclid project and outside astronomy by companies through the Target Fieldlab project at the University of Groningen. It is also in use for the LOFAR data and used by INAF Italy for the VLT Survey Telescope.

In addition, OmegaCEN has expanded to include NOVA's instrumentation flagship METIS, ESA's Planetary Defense programme and ESO's VLT science pipeline software development and maintenance. OmegaCEN is developing an extensive archive to handle the >1 Petabyte of (science detector) data produced during METIS' Assembly, Integration and Verification (AIV) phase.

A joint NOVA Long-Term Archiving and ESA programme discovered and recovered asteroids in existing wide field imaging archives, including potentially dangerous Near Earth Objects (NEOs). The OmegaCAM archive was used as a proof of concept and 196 NEO appearances were pre-covered from 400,000 CCD images with ~0.12" (2D) accuracy. As a consequence 3 NEOs were removed from the ESA + NASA Risk List.

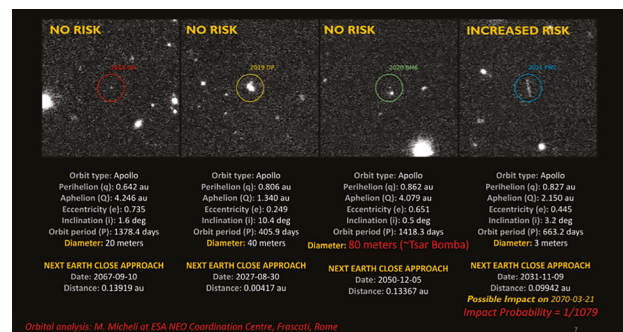

First results of a joint NOVA-LTA and ESA programme to search for discovery or recovery of potentially dangerous Near Earth Objects in existing wide field archives [4].

LO-FASTR

Through the LO-FASTR project, NOVA delivered software to link the new LOFAR COBALT2.0 beamformer-correlator with the DRAGNET GPU cluster in order to create a near-real-time system for searching for rapidly spinning millisecond pulsars and high-redshift fast radio bursts. These exotic astrophysical sources give a unique view of extreme astrophysics in action, and they also serve as exceptional probes of gravity, dense matter, and the magneto-ionic media that lie between stars and galaxies. LOFAR is a powerful telescope for surveying the sky for rare transient events, but operating at millisecond timescales requires substantial computing power to operate in real time. While LO-FASTR delivered software tools to search existing LOFAR data, the telescope is currently being upgraded to LOFAR2.0, which will expand its field-of-view and increase the flexibility of its observing modes. During the LO-FASTR project, NOVA seed funding proved successful to obtain a much larger ERC Advanced Grant (3.5 M€; PI: Hessels), which will build an updated EuroFlash search machine fed by a next-generation COBALT3.0 beamformer-correlator. To achieve optimal sensitivity, the signals from thousands of LOFAR antennas need to be accurately combined into 'tied-array beams'. LO-FASTR developed a computationally efficient holographic method to calibrate how well different stations are added together, taking into account ionospheric and instrumental effects.

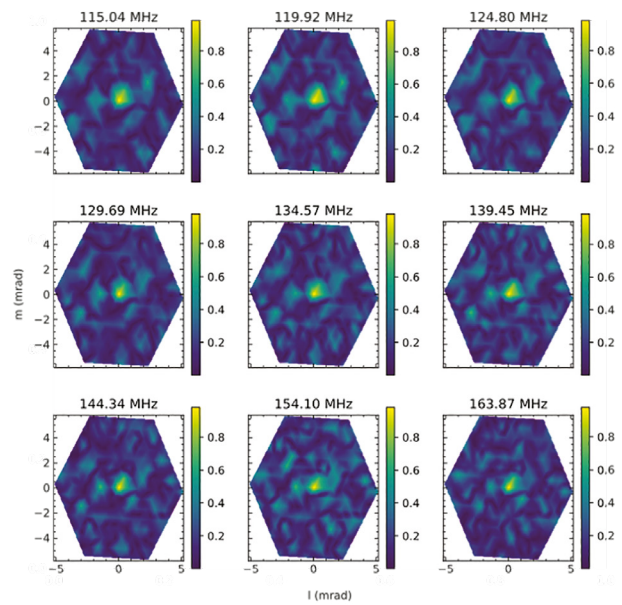

Observed tied-array beam shapes at different frequencies from the LOFAR High-Band Antenna Core stations. The plots are from an observation of 3C147 taken on 2024-02-20, and the bright points at the centres of each image demonstrate that the antennas are being added together coherently.

Lab for Astrophysics

The Laboratory for Astrophysics at Leiden Observatory is dedicated to experimentally investigating the evolution of interstellar atoms and molecules under various physical conditions, mimicking the environments found in star-forming regions, ranging from diffuse clouds to (proto-)planetary systems. To achieve this, five UHV experimental setups have been commissioned and fully upgraded in recent years. Among them, IRASIS and OASIS are used to determine the optical properties of interstellar ices, while SURFRESIDE, MATRIICES, and CRYOPAD are designed to study ice chemical reactions at the atomic level. NOVA provides crucial funding for continuity of the laboratory and it has proven to be a successful lever to obtain additional funding.

In 2022–2024, research at the laboratory focused on two major directions: understanding the efficiency of chemical processes that increase interstellar molecular complexity, and spectroscopically characterizing the resulting species in ways that directly support astronomical observations across the UV to IR range. A key highlight was the discovery that complex organic molecules can form efficiently through reactions triggered by single carbon atoms, leading to the production of methane [5] and ethanol [6], as well as by the simplest alkyne (C_2H_2), resulting in ethanethiol [7] and various alkanes [8]. While many of these molecules have been identified in the gas phase, their detection in the solid phase remains limited, particularly for

sulfur-containing species. To address this, a detailed spectroscopic study of sulfur salt (NH_4SH), a likely reservoir of interstellar sulfur, was conducted [9], shedding light on the elemental balance between gas and ice in space.

Amidst these scientific achievements, the laboratory itself underwent a major transition. It was relocated to the new Gorlaeus Building in summer 2024, which was celebrated with an opening ceremony in November 2024.

References:

- [1] Event Horizon Telescope Collaboration et al., 2025, *A&A*, 704, A91
- [2] Arnaudova, K. I. et al., 2024, *MNRAS*, 535, 2269
- [3] Landman, R. et al., 2025, *A&A*, 696, L1
- [4] Saifollahi, T. et al., 2023, *A&A*, 673, A93
- [5] Lamberts, T. et al., 2022, *ApJ*, 928, 48
- [6] Fedoseev, G. et al., 2022, *A&A*, 660, A7
- [7] Santos, J. C. et al., 2024, *A&A*, 690, A24
- [8] Fedoseev, G. et al., 2025, *Phys. Rev. Lett.*, 135, 043601
- [9] Slavicinska, K. et al., 2024, *A&A*, 688, A29



Lab for Astrophysics team (top) and 2024 opening event in the Gorlaeus Building (bottom).



Daniela Huppenkothen

Can you tell us about your most recent discovery or a recent development you are excited about?

For the past few years, I've been excited about the opportunities that machine learning brings to statistical analyses of astronomical data. This might sound very boring at first (at least it does to most astronomers), but statistics underpins all of our discoveries! It's how we decide whether there's an actual supernova in our images, what the temperature of a star is, and which physical processes govern accretion of matter onto black holes. Over the past decades, the astrophysical simulations used to model astronomical data have become increasingly complex and computationally expensive: from hours for radiative transfer simulations of massive stellar atmospheres, to weeks or months for cosmological simulations. A lot of my group's work has been trying to answer the question of how we can use these simulations in robust statistical inference, which often adds even more computational complexity, and what role machine learning can play in that context. We're working on neural network surrogate models across a wide range of astrophysical settings, from stellar atmospheres to Fast Radio Bursts, and from accretion onto stellar-mass black holes to ionised gas around supermassive black holes. To astronomers, this can look like total scientific chaos, but all of our projects are tied together by fundamental similarities in the types of data they use and the analysis methods those data require. It's been really fun to see the many ways machine learning can accelerate astrophysical modelling — not only making existing analyses more efficient, but also allowing us to ask questions that were previously impossible to answer.

If you could share one message about astronomy with the general public, what would it be?

As astronomers, I think we often forget not just how amazingly huge the scales of the universe are, but also how marvellous the process of doing astronomy is in itself. All we have are faint pinpricks of light (or the occasional gravitational wave, or a handful of particles) and from those, we've learned so much about our universe. Unlike most other fields, we can't visit our objects of study or run controlled experiments. All we can do is sit here on Earth with our telescopes and wait for the universe to do something interesting. And every time we think we've figured out the major phenomena, we build a new telescope and the universe gives us something new and unexpected. To me, knowing that there are many more surprises still to come, is one of the most exciting parts of being in this field of study.

What do you hope to achieve in your professional work over the next year, and what role could NOVA play?

Over the next year, I'm hoping to do so many things! My group's work is driven by one central question: how do we extract the most useful astrophysical knowledge from our data? Our projects currently span a huge range — from interstellar molecules and massive stars to Fast Radio Bursts and black holes — and we're exploring neural networks and simulation-based inference in various ways. I think those tools hold a lot of promise for learning astrophysics directly from data. Beyond research, I've really been enjoying university teaching and have lots of ideas for bringing more data science into physics and astronomy curricula. And I've always been a community organiser, so I'm hoping to bring the Dutch astronomy community together a bit more around data science. I've already started some events together with the AI/Maths Network, but I think there's more potential there, so stay tuned!

How do you experience being an astronomer in the Netherlands and being part of NOVA?

I'll start with the caveat that I wouldn't really call myself an astronomer at this point. While the data I work with and much of the scientific motivation behind my research comes from astronomy, what I actually do is apply statistical and machine learning methods, and develop new techniques and software for scientific data analysis.

That said, I really appreciate the collaborativeness of the Dutch astronomy community. My research is by its nature very collaborative and interdisciplinary, and the community here has been a great environment for someone like me. It's very tight-knit, with a lot of cooperation on many different things, whether that's large funding proposals or individual scientific projects. As someone hired through the Sectorplan for data science in astronomy, I'm part of a whole cohort of researchers and support staff hired as part of NOVA and the broader Dutch community, and it's really exciting to be part of a community-wide effort.

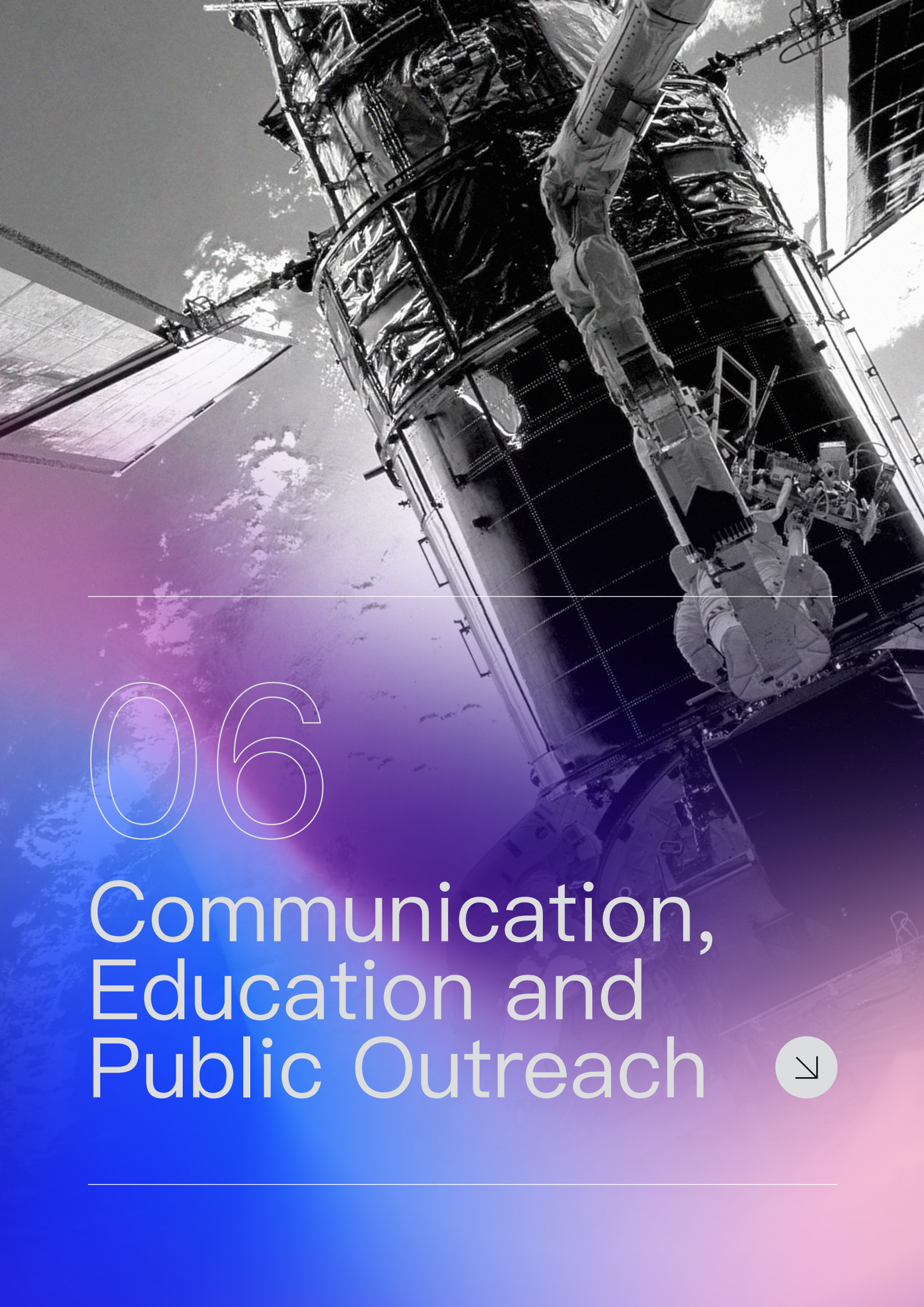

06

Communication,
Education and
Public Outreach



The NOVA Information Centre (NIC, located in Amsterdam) was established by NOVA and its four university-based astronomical institutes to execute, promote, and coordinate activities in public outreach (communication and education) in the Netherlands on discoveries in astronomical research in general and results obtained by astronomers in the Netherlands in particular.

The four institutes at the University of Amsterdam, the University of Groningen, Leiden University, and Radboud University organize their own outreach and educational activities. The vision and strategy which is outlined below is also applicable to the local and regional public outreach and education activities. Examples of local outreach are stargazing nights, sidewalk astronomy, dark sky projects, the library telescope, Astronomy on Tap, open days and organizing activities with schools in the region.

Vision & Strategy

The communication vision and strategy redesigned in 2018 in the document **NOVA Information Centre Vision and Strategy 2025**, is still leading in the years 2022–2024, but needs an update in the changing communication and media landscape from 2025 on.

Vision

1. Engage society in modern astronomical research and share the thrill of scientific discovery;
2. Foster enthusiasm for astronomy in particular, and other natural sciences and technology in general through education;
3. To reach as many members of the general public and school youth as possible and to be inclusive in this process.

Strategy

Since the start NOVA/NIC acts as initiator, innovator, expertise center and national hub of nationwide outreach activities in astronomy. These activities include press communication to the media, development of education materials and teaching tools, and offline and online communication with the general public. NOVA/NIC aims to consolidate and, where feasible and desired, further strengthen its position as the national coordinator and the main connector for astronomical news in the Netherlands, on behalf of NOVA, and also ESO and the IAU.

To realize its vision, NOVA makes the following strategic choices:

- Actively stimulate innovation and share best practices;
- Foster connections, partnerships and alliances in the field of astronomy and outreach;
- Continuously monitor and pro-actively benefit from and adapt to the fast changing media landscape;
- Reach children by means of the innovative and interactive mobile planetarium project ‘Bringing Astronomy into Classrooms’;
- Continued effort in primary and secondary school astronomy education;
- Expand activities in (online) teacher training in primary and secondary schools.

Goals & Target groups

The main target groups are (1) press & media, (2) school children & educators, and (3) the general public.

Prime goals of the NOVA/NIC outreach efforts are to (1) inform the public about astronomy and involve them in astronomy, (2) identify and engage with societal developments where astronomy can contribute, and (3) contribute to the teaching of the astronomy curriculum in schools.

It aims to reach these goals by communicating to selected target groups using those media and platforms that are most efficient in reaching these groups. The sizes of such target groups range from very large (e.g., the general public) to small (e.g., engineers specialized in detector technology). Communication with specific groups is both direct and indirect – and both one-way and interactive. Examples of the former are outreach via the press, social media presence, and contributing to writing high school textbooks. Examples of the latter are public events, science fairs, and school visits with the mobile planetariums.

Press & Media

As part of its communication effort, NOVA/NIC issues 50–60 press releases (in the Netherlands and abroad) and announcements annually, on behalf of all the four NOVA astronomy institutes, highlighting Dutch science results of (inter-)national importance and linking these to societal and technological developments where appropriate. A slightly lower number of ESO press releases is translated and disclosed to the Dutch public. These efforts contribute to the many hundreds of astronomy news items and features that are reported on in regional and national newspapers, websites, radio, television and social media every year, in the Netherlands and abroad.

Press releases are issued in close collaboration with the NOVA institutes, but also with ESO, ESA, SRON, ASTRON, NWO, JIVE, and institutes abroad.

The NIC also acts proactively towards media and journalists by pitching ideas for reports on a regular basis, and by organizing press visits to the big observatories and other press events.

NIC offers media training sessions at all NOVA institutes, for PhD students, postdocs and staff.

The NIC is also the Dutch national communication and press hub for the European Southern Observatory (ESO) and the International Astronomical Union (IAU).



Screenshot of a documentary shown on NTR (2023) about the first observations with WEAVE on La Palma.

Mobile Planetarium

There are currently four mobile planetariums operating in the Netherlands. Two domes are operated by the NIC and one by the University of Groningen. In 2022, a fourth dome was added through a sponsoring agreement between NOVA/NIC and SRON. This agreement covers not only the acquisition of the SRON dome, but also supports targeted outreach initiatives aimed at engaging underserved communities across the Netherlands through the NOVA Mobile Planetarium project. In addition, it provides funding for the development and implementation of new planetarium content in preparation for the future New Athena mission.

NOVA/NIC has a unique position in the mobile planetarium world, having direct access to the large community of NOVA scientists and their datasets. There is an increasing trend in bringing cutting-edge science data into the dome. This can be in the form of imagery and films, the most basic way of utilising science data in a planetarium show, or data can be used in e.g. visualisations to connect the visitor to current science.

All four domes are equipped with the same software and hardware and are run under the same licenses. The NIC coordinates and negotiates the licenses, advises about and implements upgrades, produces

and renders planetarium movies, and takes care of daily maintenance.

The NIC organized approximately 350 performance days per year, including school visits and special events for children. In addition, the University of Groningen facilitated around 35 school visits and special events annually. By 2025, the project had reached more than 500,000 children – roughly one-fifth of a full annual student cohort in the Netherlands. Participating schools contribute a modest fee to help cover transportation and personnel costs.

In 2023 NOVA/NIC was awarded – in collaboration with the NOVA Institutes – another grant from the NWA (National Science Agenda) for Science Communication (WeCom), worth 150k €. The project ‘Live, interactief én inclusief: Mobiel Planetarium naar elke school’ focuses on actively approaching missed target groups: underserved neighbourhoods in the big cities and rural areas. For disadvantaged neighbourhoods, there was a close collaboration with the IMC Weekend School Foundation, both in terms of free visits, the development of the training programme and the evaluation of its impact. This will enable a significant (and sustainable) step towards the goal: to offer all schoolchildren in the Netherlands this unforgettable experience.



Alumni of Stichting IMC Weekendschool were among the first visitors of the new mobile dome. Credit: SRON/Frans Stravers.

Omniversum

The collaboration with the Omniversum in The Hague, the largest dome theatre in the Benelux has been intensified. NOVA/NIC organized the monthly planetarium shows (the so-called Star Parties), with each year four show with a special theme, with a guest speaker from the scientific field. Starting in 2022, NOVA/NIC also structurally offers planetarium shows in Omniversum to schools in The Hague and surrounding areas. NOVA/NIC is collaborating with third parties (e.g. for Dome Concerts) to bring astronomy to a broader audience by combining planetarium content with music concerts.



Planetarium Show in the Omniversum theater in The Hague

Networks

The NIC officers maintain strong connections with, and play important roles in, national press communication and education organizations, like board membership of the Vereniging van Wetenschapsjournalisten (VWN). Baan is the ESO media representative in the Netherlands. Holt is board member of the Dutch/Belgium planetarium society Planed and a member of the International Planetarium Society IPS. Both Baan and Holt are IAU-National representatives for Outreach and Education. Baan was also elected as secretary of the Organizing Committee of the IAU Commission C2 (Communicating Astronomy with the Public).

Channels

A broad range of channels is used for communicating and interacting with press, schools and the general public. Examples include press releases, media pitches, website (news, phenomena in the night sky, agenda for talks and events, all on a daily basis), a newsletter with ~ 4000 people subscribed, mainly working in education, posters, social media, Q&A email service, and events (science fairs, movie festivals, star gazing activities).

Other educational activities

The rapid growth of the planetarium project, the new NWA grant, the collaboration with Omniversum and issues with the available human resources have led to a shift in priorities, with other educational activities being temporarily suspended or continued at a minimum level. The DIY spectroscopes were still very successful. Teacher trainings and the collaboration with educational publishers have been on the back burner in the years 2022–2024, although NOVA/NIC was present at the annual Woudschoten-conferences for physics teachers with workshops and an information stand.



Joris Hanse

Can you tell us about your most recent discovery or a recent development you are excited about?

In our planetariums we try to communicate about all exciting frontiers of astronomy. And the fun thing is that the kids we teach are often as excited as we are about those topics. Black holes, the Big Bang and early universe, star and planet formation, gravitational waves, dark matter, exoplanets, alien life, etc. I try to stay up to date as much as possible. And we have to, because kids read the news and will ask us about those discoveries. It's fun and challenging to translate the latest science into language that they understand.

How do you experience being an astronomer in the Netherlands and being part of NOVA?

Being an educator in the same organization as professional astronomers is really valuable. Within the NOVA Information Center we are on top of the latest science and take this into the dome. In the Omniversum in The Hague we give public lectures with NOVA scientists every few months and tell the audience about the latest developments in, for example, JWST science, the BlackGEM project and exoplanet research. Also in our mobile domes, our astronomy students, who are teaching the kids, tell the audience about their own research.

What do you hope to achieve in your professional work over the next year, and what role could NOVA play?

There's a lot. In the next few years we have two fun new projects: we will bring Athena and Gaia science into the dome. We also have funding to broaden our audience. As with a lot of science communication initiatives, we are having trouble reaching underprivileged groups both in cities and in the countryside. We have started a project to reach those groups and try to make sure that many more kids have a fun experience in the planetarium and may be inspired by astronomy and science in general.

If you could share one message about astronomy with the general public, what would it be?

Communicating astronomy is what we do every day. Our job is pretty easy: we have cool stories and cool visuals and it's easy to get people hooked. Sometimes people in the dome ask: what use is astronomy, why should we invest money in it? There are a lot of answers to this question, but for me personally it's quite simple. Almost everyone is fascinated by those fundamental questions that astronomy asks. Isn't that reason enough, to try to get closer to answers to those questions and satisfy that inherent interest in knowledge about what's out there and where we come from?

Visit to ESO's telescopes in Chile

with the Minister of Education, Prof. Robbert Dijkgraaf

In January of 2024 a unique visit to ESO's telescopes in Chile took place. This visit had its origins over a year earlier, in September 2022, when an event was organized in Leiden to celebrate the 60th anniversary of ESO. The Minister for Education, Culture and Science (OCW) Prof. Robbert Dijkgraaf attended that event and was invited by ESO's Director General (DG) Prof. Xavier Barcons to come to Chile for a visit of ESO's facilities.

NOVA had a large role in planning and organising the visit, which took place from January 8th to 12th 2024. Besides the Minister, the ministry delegation also included the OCW Director for research and science policy, Oscar Delnooz, and Mirjam Lieshout-Vijverberg, the Ministry's representative on the ESO Council. The Dutch ambassador to Chile, Ms. Carmen Gonsalves, accompanied the minister in Chile, as did the ESO DG. Prof. Amina Helmi, the Dutch scientific delegate on the ESO Council took part, while NWO was represented by Prof. Jan de Boer, chair of the Domain Board for Exact Sciences. NOVA was represented by members of the Board and Directorate, as well as three of the deans of the NOVA Oversight Board. Kees Buijsrogge, director at TNO, one of our closest industrial partners, also participated.

The five days in Chile took us on a fast-paced trip to the different sites of the ESO observatories. On Monday, the day of arrival, we were welcomed by the ESO DG and the Dutch ambassador at a reception at the ambassadors' residence in Santiago. The next day we were off to La Silla where we toured the various telescopes. At sunset the official opening of the NOVA/Nijmegen-led BlackGEM telescope array took place, with Minister Dijkgraaf performing the ribbon cutting. In the evening there was an opportunity to enjoy and observe the amazing night sky. On the third day, the delegation travelled on to the Paranal observatory where ESO's Director of Operations, Dr. Andreas Kaufer, gave a presentation on ESO's VLT and ELT telescopes. Amina Helmi and Michiel Rodenhuis presented the strong NOVA collaboration with ESO in both astronomical research and instrumentation. In the

afternoon we visited the ELT technical facility, including the mirror coating facility. This was followed by a visit of the VLT telescopes at twilight, with the laser guide stars of UT4 (Yepun) stealing the show. The final stop was a visit to the VLT operations room.

On the fourth day, the morning was perhaps the climax of the trip, with a visit of the ELT under construction. A souvenir, a picture of the ELT, was signed and a copy given to the Minister and the ESO DG. The afternoon was spent on a long bus ride to the ALMA observatory with Kees Buijsrogge memorably giving a presentation on the strong role astronomy plays in the Dutch high-tech ecosystem of over an hour while standing in the aisle of the bus. The final day was spent visiting the ALMA OSF and the high site on the Chajnantor plateau where the telescopes operate. In the afternoon, the delegation flew back to Santiago where the visit was officially concluded.

The visit was a splendid opportunity to not only showcase the strong position of Dutch ground-based astronomy to the ministry, but also the European leadership in this field and the strong spin-off this has for our industry and technology position. We were very pleased with the unexpected positive effects: a week later Minister Dijkgraaf had to answer questions in Parliament and took the opportunity to show a few pictures of the trip, a first in Dutch parliamentary history. In his speech to Parliament, the Minister said: "One of the areas in which the Netherlands is leading the way is in astronomy. We have one national research school, NOVA, which is a beautiful example of how we work collectively". We have later been told that the visit also played a role in producing the Draghi report on the future of European competitiveness, to which Minister Dijkgraaf made important contributions.

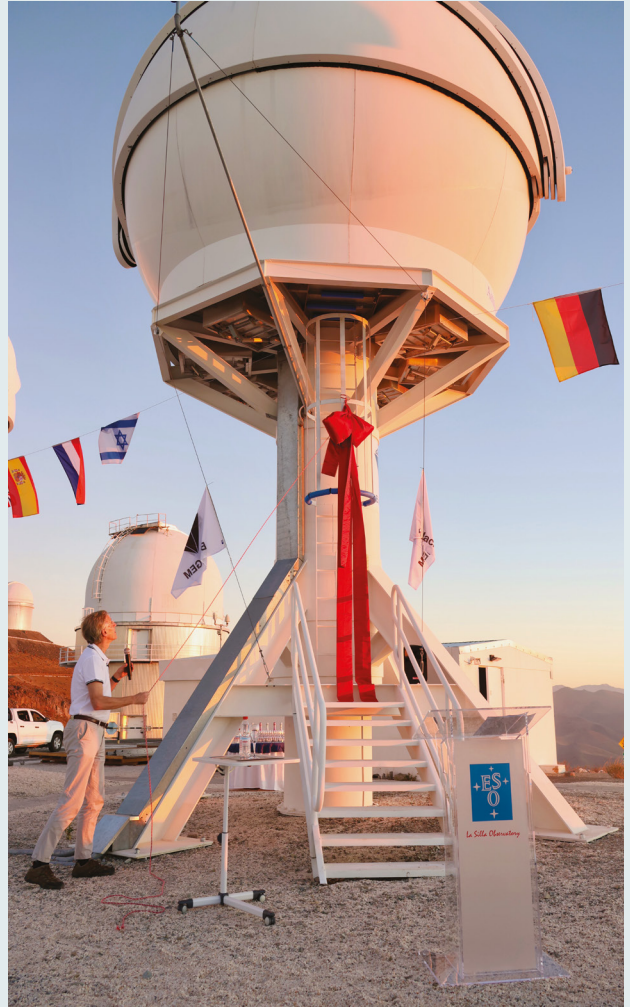
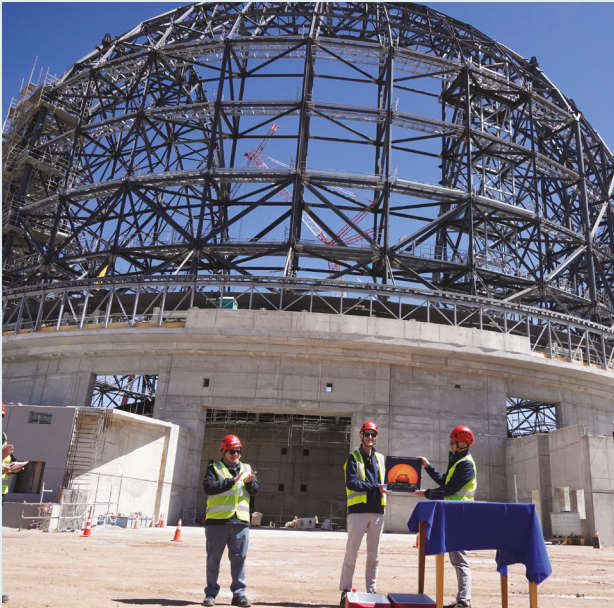



07

PhDs in
Astronomy



PhDs in Astronomy 2022 – 2024

All NOVA PhD candidates are required to attend the NOVA PhD School at least once, usually in their first or second year. The school lasts one week and offers two parallel lecture streams. Students are encouraged to attend lectures that are less directly related to their own research topic in order to broaden their academic perspective.

The programme also includes overviews of the Dutch astronomical research landscape, with presentations on NOVA, ASTRON, and SRON. In addition, workshops

are offered on scientific writing and outreach, and participants give short presentations on their own research projects.

In their third year, NOVA PhD candidates attend the annual PhD Weekend, which focuses on career development, both within and outside academia. The programme features talks by alumni as well as workshops on presentation skills and navigating the academic and non-academic job markets.

The following activities were organised between 2022 and 2024:

PhD Weekend:

- 24–25 June 2022
- 16–17 June 2023
- 24–25 May 2024

PhD School:

- 27–30 November 2023

NAME	PhD DATE	PROMOTOR	THESIS TITLE
Ahad, S.L.	21/11/2023	Hoekstra, Bahé	Probing Cosmic Monsters – Confronting Hydrodynamic Simulations with New Observations of High-density Environments
Ardévol Martínez, F.	08/10/2024	Kamp, Palmer, Min	Machine learning for exoplanet characterisation in the JWST era
Awad, P.	30/09/2024	Peletier, Bunte	From the Large-Scale Structure to the Milky Way halo
Backs, F.R.N.	21/11/2023	de Koter, Kaper	Massive stars – before and on the main sequence
Barr, A.	22/04/2022	Tielens, Boogert	The Infrared Spectrum of Massive Protostars: Circumstellar Disks and High Mass Star Formation
Basak, A.	23/10/2024	Uttley, Wijnands	Decoding accretion mysteries – Spectral-timing insights into black hole and neutron star X-ray binaries
Boersma, O.M.	23/11/2023	Wijers, van Leeuwen	In unison – Observations and predictions of compact-object merger emission
Born, J.A. van den	09/05/2023	Tolstoy, Jayawardhana, Jellema	The MICADO atmospheric dispersion corrector
Brands, S.A.	07/06/2023	de Koter, Kaper	Clumped outflows of the massive stars in the Large Magellanic Cloud
Bremer, J.G.	05/12/2022	Dayal, Peletier	From the nature of dark matter to the escape of hydrogen ionizing photons
Burggraaff, O.	13/12/2022	Keller, Vijver, Snik	Accessible remote sensing of water
Butler, K.M.	14/09/2023	van der Werf, Hodge	Neutral Outflows in High-Redshift Dusty Galaxies
Canas Herrera, G.	19/10/2022	Achúcarro, Silvestri	Playing dice with the Universe: Bayesian Statistical analyses of cosmological models and new observables
Caglar, T.	21/12/2022	Brandl, Brinchmann, Burtscher	A well-established harmony in chaos
Chaikin, E.	27/02/2024	Schaye, Schaller	Withstanding the cold: energy feedback in simulations of galaxies that include a cold interstellar medium
Choque Challapa, N.C.	28/06/2022	Peletier, Verheijen, Aguerri	The evolution of dwarf galaxies in clusters
Contigiani, O.	26/01/2022	Hoekstra, Silvestri	Exploring the edge
Cooper, A.J.	16/12/2022	Wijers, Rowlinson	Multi-messenger & multi-wavelength signatures of compact object transients
Das, P.	24/06/2024	Watts, Porth	Zooming in and out

Deb, T.	10/05/2022	Verheijen, van der Hulst, Poggianti	Atomic hydrogen discs as tracers of galaxy transformation in Abell 2626 and beyond
Debackere, S.	22/09/2022	Schaye, Hoekstra	Aggravating matters: Accounting for baryons in cosmological analyses
Delgado Giler, A.G.	23/01/2024	Vecchi, de Souza, Peletier	Study of cosmic-ray composition with Imaging Atmospheric Cherenkov Telescopes
Derkink, A.	12/06/2024	Kaper, de Koter, Ramirez-Tannus	Watching young stars grow up
Dodd, E.L.	10/12/2024	Helmi, Starkenburger	Galactic ancestry in the Gaia era
Dufour, G.	21/06/2022	Linnartz, Charnley	Non-linear Astrochemical Kinetic: Theory and Applications
Eappachen, D.	20/11/2023	Jonker, Rossi	The origin of fast X-ray transients
Eftekhari, F.S.	19/12/2023	Peletier, Mieske	The inner-workings of dwarf galaxies in the Fornax Cluster
Erceg, A.	20/12/2024	Jelic, Haverkorn	Faraday tomography of LoTSS-DR2 data
Evans, F.A.F.	15/03/2023	Rossi, Kuijken	Far From Home: the science exploitation of the fastest Milky Way stars
Ferronato Bueno, E.	06/12/2022	van den Berg, Vecchi, Barao	On the measurement and interpretation of the fluxes of galactic cosmic-ray nuclei
Flöss, T.A.	17/09/2024	Roest, Koopmans, Meerburg	A skewed perspective on the universe advancements, challenges and prospects in the hunt for primordial non-Gaussianity
Fodran, T.	16/09/2024	Horändel	Commissioning the Auger prime radio detector: paving the way for mass separation
Frias Castillo, M.	20/06/2024	van der Werf, Hodge	Measuring cold molecular gas across cosmic times
Gamez Rosas, V.	19/12/2023	van der Werf, Jaffe	The dust and molecular gas in the torus of NGC 1068
Gan, H.	06/10/2022	Koopmans, Wilkinson	Hunting elusive excess variance in big LOFAR data
Gao, F.	22/11/2022	Caputi, Wang	Growing supermassive black holes and magnificent star factories in the Universe
Gaspar da Silva, J.R.	20/09/2022	van der Tak, Gao	Terahertz superconducting hot electron bolometer heterodyne array receivers for NASA's GUSTO balloon observatory
Gelder, M.L. van	24/11/2022	van Dishoeck, Hogerheijde, Tabone	Molecular inheritance from cloud to disk
Gludemans, A.J.	18/10/2023	Rottgering, Duncan	Extremely Loud & Incredibly Far – Observing Radio Bright AGN into the Cosmic Dawn
Gogate, A.R.	21/03/2022	Verheijen, van der Hulst	An HI perspective on galaxies 2.5 billion years ago
Gomes Rachid, M.	09/05/2023	Linnartz, van Dishoeck	The Hunt for Frozen Organic Molecules in Space

Graaff, A. de	15/09/2022	Franx, Bezanson	Shaping Massive Galaxies
Guo, D.	13/05/2022	Kaper, Brown	A Gaia census of young moving groups in the solar neighborhood
Gvozdenko, A.	26/02/2024	Larsen, Beasley	Star clusters near and far. The puzzles of their chemical compositions.
Hewitt, D.M.	16/12/2024	Hessels, Degenaar	Following the flashes: Monitoring and localising repeating fast radio bursts
Inkenhaag, A.	25/09/2024	Jonker, Levan	The importance of the environments of transients
Izquierdo Cartagena, A.F.	01/12/2023	van Dishoeck, Testi, Facchini	Mining the kinematics of discs to hunt for planets in formation
Jacobs, B.	18/11/2024	Desert, Watts	Unravelling extreme close-in exoplanet climates
Juránová, A.	12/06/2024	Uttley, Costantini	Mapping the ionised gas in active galactic nuclei with spectral-timing and spectroscopy
Jurlin, N.	13/09/2022	Morganti, Barthel	Timing the cycle of life and death of radio galaxies using LOFAR
Kantzas, D.	05/10/2022	Markoff, Vink	Exploring the implications of hadronic particle acceleration in X-ray binaries
Kanwar, J.	03/12/2024	Kamp, Woitke	The warm chemistry in planet-forming disks
Käufer, T.	29/10/2024	Kamp, Woitke, Min	Unlocking a Bayesian view on protoplanetary disks
Kavanagh, R.	15/11/2022	De Almeida Vidotto, Snellen	Tuning in to star-planet interactions at radio wavelengths
Khorshid, N.	15/11/2023	Dominik, Desert, Min	Tale of a giant
Kim, Y.	04/07/2023	Telea, Trager, Roerdink	Visual exploration of high-dimensional data using dimensionality reduction: with Applications in Astronomy
Koop, O	17/12/2024	Helmi, Fraternali	The dynamic Milky Way in the Gaia era
Kukreti, P.	10/10/2023	Morganti, Oosterloo	From birth to maturity: tracing the evolution and impact of radio galaxies
Landman, R.	11/06/2024	Snellen, Keller	High-contrast spectroscopy of exoplanet atmospheres
Lange, K.	17/01/2024	Dominik, Tielens	Hidden in the dark. Seeking the vanished polycyclic aromatic hydrocarbons in planet-forming discs
Laplace, E.C.	14/01/2022	de Mink, Kaper, Justham	Late evolution, death, and afterlife of stars stripped in binaries
Leemker, M.	14/02/2024	van Dishoeck, Hogerheijde, Booth	Freezing conditions in warm disks
Legrand, L.	16/01/2023	Dayal, Koopmans, Hutter	The emergence of galaxies in the epoch of reionization

Li, A.	31/01/2023	Trager, Fraternali, Verheijen	Investigating the origin of gas flows at the disc–halo interface of local galaxies
Li, S.	25/10/2023	Kuijken, Hoekstra	Cosmic tomography with weak gravitational lensing
Mancera Piña, P.E.	05/07/2022	Fraternali, Oosterloo, Adams	Dark matter and angular momentum in nearby disc galaxies
Mesquita, A.L.	25/10/2022	De Almeida Vidotto, Snellen, Rodgers–Lee	Exploring the interactions of M dwarf winds and cosmic rays
Mierlo, S.E. van	19/03/2024	Caputi, van der Werf	New insights and predictions on high–redshift galaxies from wide–area infrared surveys
Modiano, D.	15/12/2022	Wijnands, Groot	Searching for transients in the ultraviolet
Mostert, R.	25/01/2024	Röttgering, Morganti, Duncan	Machine learning for radio galaxy morphology analysis
Murthy, S.N.	08/02/2022	Morganti, Oosterloo	A multifaceted view of the interplay between gas and radio AGN
Nazari, P.	13/02/2024	van Dishoeck, Tabone, Rosotti	Bridging the gap between physics and chemistry in early stages of star formation
Nimmo, K.	16/09/2022	Hessels, Paragi, Marcote	Zooming–in on the sources of fast radio transients
Oei, M.S.S.L.	12/12/2023	Röttgering, van Weeren	Giant galactic outflows and shocks in the Cosmic Web
Osinga, E.	01/11/2023	Röttgering, van Weeren	Untangling cosmic collisions: a study of particle acceleration and magnetic fields in merging galaxy clusters
Paneque Carreno, T.	13/09/2024	van Dishoeck, Miotello	Unveiling the third dimension: vertical structure as a probe of planet formation conditions
Panwar, V.	12/01/2023	Desert, Dominik	Advances in ground–based characterization of transiting exoplanets using novel data analysis methods
Pastor–Marazuela, I.	01/11/2022	van Leeuwen, Wijers	Exploring the link between neutron stars and fast radio bursts
Peirano Bastías, V.C.I.	13/06/2023	Mendez, Garcia	The rhythm of accretion: time lags of the fast variability in X–ray binaries
Poorta, J.	08/07/2024	Kaper, de Koter	Intermediate to high–mass pre–main–sequence stars and their disks
Portilla Revelo, B.A.	05/12/2023	Kamp, van Dishoeck	Closing the gap between theory and observations of planet–forming disks with radiative transfer models
Raaijmakers, G.	07/12/2022	Nissanke, Watts	Probing neutron star interiors with multi–messenger observations
Ramos Padilla, A.F.	22/11/2022	Trager, van der Tak, Wang	Diagnosing the ISM of galaxies and energetic processes in a cosmological context
Reino, S.	27/09/2022	Rossi, Kuijken, Sanderson	Galactic substructures as tracers of dark matter and stellar evolution

Rezaei Badafshani, S.	27/06/2022	McKean, Biehl	Deep learning in high angular-resolution radio interferometry
Rinaldi, P.	10/12/2024	Caputi, Fraternali	Unfolding the early Universe with JWST
Rosani, G.S.G.R.	24/01/2022	Caputi, Barthel, Caminha	High-redshift Lyman- α emitters in blank and lensing fields
Ruiter, I.	01/10/2024	Wijers, Rowlinson	Low-frequency radio transients: systematic search methods and characterization
Saifollahi, T.	22/03/2022	Peletier, Valentijn, Knapen	Understanding the extreme classes of dwarf galaxies
Selvi, S.	04/09/2024	Markoff, Porth	From the death of a star to the death star – magnetic reconnection in black hole magnetospheres
Serindag, D.B.	06/10/2022	Snellen, Kenworthy	Exploring strange new worlds with high-dispersion spectroscopy
Shankar, S.	09/04/2024	Watts, Moesta	End-to-end modelling of magnetorotational core-collapse supernovae
Simoni, R.S.	24/01/2022	Vink, Berge, Wijers	Studies of supernovae and their remnants based on gamma-ray observations with H.E.S.S.
Son, A.A.C.	21/12/2023	de Mink, Kaper, Hernquist	The first pieces of the gravitational-wave progenitor population puzzle
Spring, E.F.	27/09/2023	Dominik, Birkby	Between the lines: advancing exoplanet characterisation with high resolution cross-correlation spectroscopy
Stapper, L.M.	16/10/2024	van Dishoeck, Hogerheijde	A Herbig disk view of planet formation
Stofanová, L.	13/11/2024	Kaastra, Schaye, simionescu	From atoms to the cosmos: exploring the cosmic web beyond collisional ionisation equilibrium
Stoop, M.P.	15/11/2024	Kaper, de Koter	The early evolution of young massive clusters – A Gaia study of OB runaways
Stoppa, F.	27/05/2024	Nelemans, Cator	The numbers behind stars and galaxies
Sturm, J.A.	23/10/2024	van Dishoeck, McClure	Breaking the ice: constraining the volatile distribution in protoplanetary disks
Sutcliffe, B.J.	08/06/2023	Markoff, Birkby, Kenworthy	Bringing exoplanets into sharper view. Storm chasing on distant worlds
Sweijen, F.	11/04/2024	Röttgering, van Weeren	Prying eyes on radio skies: pushing the high-resolution low-frequency frontier with LOFAR
Taghribi, A.	15/11/2022	Bunte, Peletier, Biehl	Natural computation techniques for uncovering low-dimensional topological structures in large scale astronomical simulations
Timmerman, R.	22/11/2023	Röttgering, van Weeren	Tuning in to the Feedback Bassline – Revealing the operation of AGNs in galaxy clusters with high-resolution radio observations
Valegård, P.G.	26/01/2024	Dominik, Ginski	The evolutionary state of young protoplanetary disks

Vasquez Beltran, M.A.	27/05/2022	Jayawardhana, Peletier, Huisman	Multi-loop hysteresis and recursive remnant control
Veronesi, N.	08/11/2024	Rossi, Kuijken, van Velzen	On a quest to discover where stellar-mass black holes merge
Verro, K.	18/10/2022	Trager, Peletier	The X-shooter Spectral Library and stellar population models
Visser, R.	30/11/2022	Dominik, Ormel	From pebble to planet: the growth, rotation and structure of planetary bodies formed from pebbles
Viswanathan, A.	06/12/2024	Starkenburg, Helmi	Mapping the ancient Milky Way through metal-poor stars
Vlugt, D. van der	06/12/2023	Röttgering, Hodge	A radio view of dust-obscured star formation
Vos, J.	18/11/2024	Moscibrodzka, Cerutti	Theoretical perspectives on magnetic reconnection in black hole accretion
Wateren, M. van der	06/10/2024	Nelemans, Bassa, Janssen	Illuminating the properties of radio pulsars and their binary companions through pulsar timing
Wijers, N.A.	16/03/2022	Schaye, Kaastra	X-raying extragalactic gas: warm-hot gas in the EAGLE simulations
Wilding, G.	15/11/2022	van de Weijgaert, Vegter, Efstathiou	Multi-scale Connectivity and Hierarchical Topology of the Cosmic Web
Wilhelm, M.	15/02/2024	Portegies Zwart, Miguel	Turtles all the way down: multiscale simulations connecting star and planet formation
Wingerden, P. van	10/10/2023	van Lunteren, Weber	Layered Loyalties: The Natuurkundige Commissie in the Netherlands Indies (1820–1850)
Woelfer, L.	28/03/2023	van Dishoeck, Ercolano	Ingredients of the planet-formation puzzle – Gas substructures and kinematics in transition discs
Zhang, X.	29/06/2022	Kaastra, Simionescu	From intracluster medium dynamics to particle acceleration
Zhang, Y.	26/09/2023	Méndez, Altamirano	The accretion-ejection coupling in Galactic accreting black holes
Zhang, Y.	06/06/2023	Snellen, Kreidberg	Isotopes and the characterization of extrasolar planets
Zheng, X.	27/09/2023	Röttgering, Duncan	The characteristics of galaxies with powerful radio jets
Zhu, Z.	30/10/2024	Kaastra, Simionescu	X-Raying the hot gas in the outskirts of galaxy clusters
Zieba, S.	25/06/2024	Snellen, Kreidberg	Pushing the characterization of exoplanet atmospheres down to temperate rocky planets in the era of JWST
Zilinskas, M.	24/05/2023	Miguel, Snellen	Lava worlds: characterising atmospheres of impossible nature
Zoutendijk, S.L.	14/12/2022	Kuijken, Schaye, Brinchmann	Lights in a sea of darkness

Financial report

APPENDIX

NOVA triennial report 2022–2024

Amounts in k€

EXPENDITURE	2022	2023	2024
ASTRONOMICAL RESEARCH			
Investment in Staff Positions	349	295	333
Formation and Evolution of Galaxies	617	255	143
Formation of Stars and Planetary Systems	580	280	171
Astrophysics of Black Holes & Neutron Stars	501	299	119
Total Research Networks	1 698	834	433
Community support	28	49	122
New Initiatives	–	119	20
Research projects / Miscellaneous	192	44	19
Total Other Research Activities	220	212	161
TOTAL ASTRONOMICAL RESEARCH	2 267	1 341	927
INSTRUMENTATION			
<i>ELT Instrumentation</i>			
ELT METIS	2 655	2 911	3 812
ELT MICADO	1 005	979	1 583
ELT MOSAIC	114	149	350
ELT PCS (EPICS) R&D	22	50	123
<i>Other Op-IR Instrumentation</i>			
WEAVE	19	68	299
BlackGEM	57	4	2
HARPS3	258	88	5
4MOST	177	72	11
NUX	32	47	2
Projects with industry	–	100	17
NOVA Op-IR group	267	237	490

Sub-mm instrumentation

ALMA Band 2	908	1 046	3 173
ALMA Band 9 R&D	48	17	385
Llama/Band 6	15	3	63
CTA	86	105	96
Sub-mm R&D	25	228	187

Participation in space missions

Euclid	238	109	93
Gaia	98	8	6
MIRI	111	227	136
nEXTsPec	—	—	41
Space instrumentation R&D	105	230	271

Other Projects

Laboratory astrophysics	—	—	16
Support previous projects	— 47	—	9

TOTAL INSTRUMENTATION	6 192	6 678	11 170
------------------------------	--------------	--------------	---------------

OFFICE & OUTREACH

NOVA Office	593	1 366	627
NOVA Information Centre	259	272	325

TOTAL OFFICE & OUTREACH	852	1 638	952
------------------------------------	------------	--------------	------------

TOTAL EXPENDITURE	9 311	9 657	13 049
--------------------------	--------------	--------------	---------------

REVENUES	2022	2023	2024
NOVA Grant (OCW)	6 218	6 621	—
Sectorplan (OCW)	1 944	3 740	3 933
NWO	992	511	2 324
ESO	1 426	3 885	3 801
External funding ESA/NSO	106	40	253
Other universities	562	631	10
Industrial contracts	51	1	30
Miscellaneous	40	—	82
TOTAL REVENUES	11 339	15 429	10 433

NEDERLANDSE ONDERZOEKSCHOO
VOOR ASTRONOMIE

NETHERLANDS RESEARCH
SCHOOL FOR ASTRONOMY



POSTAL ADDRESS

P.O. Box 9513
2300 RA Leiden, The Netherlands

PHONE

+31 (0)71 527 5852

E-MAIL

nova@strw.leidenuniv.nl

WEB

www.nova-astronomy.nl

ADDRESS

Gorleus Building
Einsteinweg 55
2333 CC Leiden, The Netherlands

PUBLIC OUTREACH

NOVA Information Center Web: www.astronomie.nl

NOVA is the alliance of the astronomical institutes of the universities of Amsterdam, Groningen, Leiden and Nijmegen, legally represented by Leiden University.

